



RAM

RAM 1500
LIMITED



NEW ZEALAND'S MOST LUXURIOUS FULL-SIZE PICKUP TRUCK

THE RAM 1500 LIMITED PICKUP TRUCK WINS LUXURY CAR OF THE YEAR[^]

HERE'S WHY:

- ▶ Opulent materials and accents blending chrome, leather and stainless steel
- ▶ Huge 12" touchscreen screen with Uconnect[®] and navigation
- ▶ 900-Watt Premium Harmon Kardon[®] sound system
- ▶ Re-configurable centre console
- ▶ Heated & ventilated front & rear outboard seats
- ▶ Premium leather trimmed seats
- ▶ Premium accent stitching & pipe-trimmed upholstery
- ▶ 60/40 Rear reclining seats
- ▶ Active noise cancelling system
- ▶ Active-Level[™] four-corner air suspension
- ▶ Multi-link corner rear coil suspension
- ▶ Electric auto deploy side steps
- ▶ Dual pane panoramic sunroof
- ▶ Best in-class towing - up to 4.5 Tonne max braked towing capacity¹
- ▶ Powerful 5.7L V8 HEMI[®] eTorque
- ▶ 6 standard airbags including advanced multi-stage front driver & passenger airbags
- ▶ Rear Flat Floor Load Storage
- ▶ Parallel and perpendicular park assist
- ▶ 360° surround view camera
- ▶ In-floor storage bins
- ▶ Blind spot monitoring with rear cross path and trailer detection
- ▶ LaneSense[®] lane departure warning with lane keep assist
- ▶ Proximity key & remote start
- ▶ Adaptive cruise control
- ▶ Power release dampened tailgate
- ▶ Frame vibration cancelling system
- ▶ Acoustic glass
- ▶ Ram exclusive RamBox[®] Cargo Management System

[^]CARS.COM 2020. ¹Maximum braked towing capacity is subject to regulatory requirements and vehicle weight restrictions (which may require occupants and/or luggage to be restricted)



RAM 1500 LIMITED

UNLIMITED SOPHISTICATION. BENCHMARK LUXURY.

It's the Ram 1500 flagship for opulence—and it gives you just about every element of craftsmanship imaginable. Ram Limited: where there are no limits to refinement.

TOTAL COMFORT. ZERO COMPROMISE.



Properly secure all cargo. Always tow within the vehicle's capacity. Overseas model shown.

UP TO
4.5T
MAX BRAKED TOWING

POWERFUL
V8
HEMI



- ▶ Uconnect® with Navigation and 12" Touchscreen
- ▶ Multi-stage Reconfigurable Centre Console
- ▶ Active-Level™ Four-Corner Air Suspension System
- ▶ 5.7L HEMI® V8 with eTorque Mild-hybrid System with Refined Stop/Start
- ▶ Blind Spot Monitoring with Rear Cross Path and Trailer Detection

THIS IS WHAT WORKS:
LUXURY, TECHNOLOGY, CAPABILITY AND STRENGTH.



WORKHORSE ATTITUDE. THE LINES OF A WINNING THOROUGHbred.

More than ever, a Ram 1500 is tasked with multiple assignments. Fortunately, this full-size pickup is designed to accomplish every towing and hauling assignment you'd expect. This rolling powerhouse delivers it all, from

sophisticated technology to features that cover performance, safety, and class-leading functionality—and that's just for starters. The sheer opulence of the 1500 Limited ensures that this is one pickup truck focused on finishing first. This is what works. This is the Ram 1500 Limited.



LUXURY. IT'S STANDARD.

THE EXTRAVAGANCE OF PREMIUM LEATHER.

Overseas model shown.

The image shows the interior of a car, viewed from the passenger side looking towards the driver's seat. A large sunroof is visible, showing a starry night sky. The interior is dark, with leather seats and a central console. The text is overlaid on the sunroof area.

EXCEPTIONAL COMFORT.

IT'S ALL RIGHT HERE: INTERIOR QUIETNESS.
AMPLE ROOM. MULTIFUNCTIONAL CONSOLES.

FIRST CLASS ON WHEELS.



RAM 1500 MEASURES UP.

Interior quietness of only 67.1 dB. Premium materials throughout. Reconfigurable front center console. Rear flat load floor for increased leg room and greater in-cabin cargo space. Spacious rear leg room of 1147 mm. Passenger-friendly fold-down rear center console. Tablet holder for rear-seat passengers. 10-way power adjustable front driver and passenger seats including lumbar adjustment as well as three levels of adjustable seat heating/ventilation. Reclining rear seat with eight-degree recline.



HEATED AND VENTILATED FRONT
AND REAR OUTER SEATS

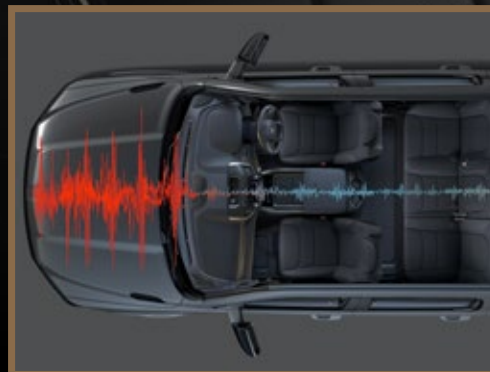

ACTIVE NOISE CANCELLING



900-WATT HARMON KARDON®
PREMIUM SOUND SYSTEM



TECHNOLOGY. IN EXTRA LARGE.

The Uconnect logo is displayed in white text against the dark background of the car's interior. The background image shows a close-up of the center console with a large touchscreen displaying a navigation map, various physical buttons, and a gear shifter.

TECHNOLOGY THAT'S SMART, FAST AND ADVANCED: HOW RAM 1500 KEEPS YOU CONNECTED WITH THE GOOD STUFF IN LIFE.

IT'S BEST, AND BEST OF ALL, IT'S CUSTOMISED BY YOU.

This is powerful, user-friendly technology that delivers premium levels of entertainment, communications, comfort and convenience—and which brings together a wealth of technologies. The Uconnect® system encompasses everything from built-in cellular connectivity to personalised settings for features like Keyless Enter 'n Go™, heated/ventilated seats and more.

12-inch reconfigurable Touchscreen with split-screen functionality and one-touch, customisable "Home Screen."

- Apple CarPlay® support



- Android Auto™ integration

android
auto



COUNT ON RAM 1500 TO GIVE YOU SUCH VERSATILITY AND CAPABILITY.

CUSTOMISE THE DISPLAY TO BEST SERVE YOUR NEEDS. INTUITIVE UCONNECT® TOUCHSCREEN LETS YOU COMMUNICATE, NAVIGATE AND STAY ENTERTAINED. FEATURES INCLUDE:

SPEAK UP and be heard; send and receive calls and texts while driving safely with hands-free phone capability.

NAVIGATE to every adventure; get turn-by-turn directions so you don't get lost on the way (unless, of course, you want to).

APPLE CARPLAY® SUPPORT.

This is smart iPhone® integration so you'll experience your favourite features through your dashboard. With Siri®, all you have to do is ask—catch up on calls and messages, get directions from Apple Maps or request a song through Apple Music®. The system lets you browse music or discover nearby petrol stations, parking, restaurants and more. Plus, Maps helps predict where you're headed.

ANDROID AUTO™ INTEGRATION.

For those who know and love Android™, Android Auto brings your favourite smartphone apps into one place, making it easier for drivers to access their favourite navigation, media and communication apps on the road while minimising the distractions. Stay focused on the road while you plan your day with Google Assistant, get voice-guided navigation with Google Maps and listen to your favourite songs on Spotify®.

Uconnect
TECHNOLOGY
FOR THE REAL WORLD

THE 5.7L HEMI® V8: 291 kW | 556 Nm OF TORQUE

NOW WITH eTORQUE TECHNOLOGY FOR A SUPPLEMENTAL 12kW OF eTORQUE POWER.

PERFORMANCE THAT RULES. Few engines carry its clout, and even fewer offer technology as efficient as eTorque and the ingenious Multi-Displacement System (MDS).



HOW A LEGEND TRANSFORMS ITSELF: THE HEMI® V8 WITH eTORQUE.

The 5.7L HEMI® V8 with eTorque—engineering incorporates an onboard electric motor to create a mild-hybrid system. Benefits are numerous, including longer 4-cylinder operation while in the MDS mode and more refined Stop/Start capability. As well, the onboard motor interacts with the regenerative braking, creating a generator which converts kinetic energy to recharge the battery system.

3 YEAR | 100,000KM WARRANTY[^]
& ROADSIDE ASSISTANCE[^]

[^]Whichever occurs first. Warranty and Roadside terms, conditions, and exclusions apply.

Overseas model shown.

OUTSTANDING RIDE AND ROAD MANNERS.

THE MULTILINK COIL SPRING
REAR SUSPENSION AND
ACTIVE-LEVEL™ FOUR-CORNER
AIR SUSPENSION SYSTEM.



A DIFFERENT WAY OF LOOKING AT SUSPENSIONS.

In general, the competition uses leaf-spring suspension technology. Ram 1500 stands alone with the comfort and durability of the rear multilink coil spring system. This coupled with the Active-Level™ Four-Corner Air Suspension System assures next-level control.

INNOVATIVE SUSPENSIONS AND
MONITORING TECHNOLOGY.



WE'RE ALL ABOUT MAKING TOWING EASIER.

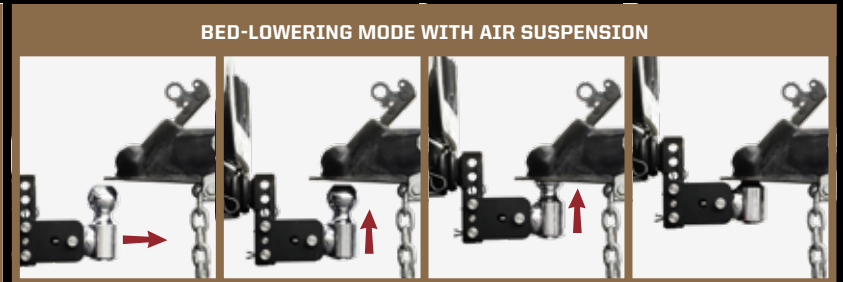

Overseas towing devices shown. Properly secure all cargo. Always tow within the vehicle's capacity.

EXTENSIVE SAFETY & SECURITY FEATURES.



SAFETY WHERE IT MATTERS MOST: ALL AROUND YOU.

LANESENSE® LANE DEPARTURE WARNING PLUS (LDW+)

Ram 1500 can read the road. Mounted on the external sideview mirrors, cameras can identify road lines, determine where the vehicle is and monitor motion. Should movement onto either line occur without use of the turn indicator, the system will warn the driver and apply torque to the steering wheel to correct the movement. If no action is taken to correct the drift, the system will automatically align the vehicle back into its correct lane position.

ADAPTIVE CRUISE CONTROL WITH STOP AND GO (ACC+)

Think cruise control that's smarter than ever. When the lanes ahead are clear, this system maintains the set speed of travel. When traffic slows, it will automatically adjust to a safe distance selected by the driver. And, while most ACC+ systems operate only down to 32 km/h, our system operates down to 0 km/h, virtually stopping the vehicle—then re-engaging back to safe-range speeds as traffic begins to move again. (Note that the system does not perform “panic stops” at speed.)

FORWARD COLLISION WARNING WITH ACTIVE BRAKING (FCW+)

This asset incorporates Grade Braking to control the transmission and automatically downshifts to maintain selected speed and distance. The system operates independently of the ACC+ system, notifies the driver if the vehicle is too close to a preceding vehicle, uses audible/visual warnings and will brake the vehicle to 0 km/h if the driver does not respond.

REAR CROSS-PATH DETECTION

When in Reverse and vehicles and/or other objects are in perpendicular relationships to your Ram pickup, dual wide-band radar sensors let you know, using illuminated icons in the outside mirrors and driver-selected chimes.

BLIND SPOT MONITORING (BSM) WITH TRAILER DETECTION

This asset monitors the blind spots on each side of the vehicle, utilising sensors in each of the side mirrors, providing audible chimes and/or visual icons to inform the driver when changing lanes, passing others or being passed. Trailer Detection senses and accounts for the length of the trailer.

THINK OF IT AS AIR POWER.



YOUR RAM 1500 AND SPACE-AGE WIND MANAGEMENT.

The better the aerodynamics, the more efficient the pickup - the Ram 1500 rules. Factors that give this pickup aerodynamics - and thus, minimal drag-include the Active Grille Shutters which adapt to speed and the sleek exterior roof shape and smart tailgate design.

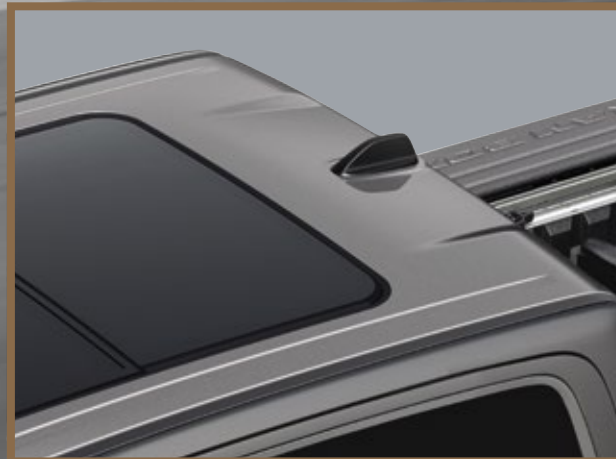

ACTIVE GRILLE SHUTTERS Active Grille Shutters instantly adapt to speed, load and engine needs to provide ideal engine cooling-while simultaneously reducing aerodynamic drag.

AERO ROOF SHAPE The Ram 1500 exterior design translates into a long wheelbase for Crew Cab models, muscular fenders and a sleek roofline that better directs airflow back to the rear spoiler. The aero roof also allowed the design of the dual-pane sunroof.

SMART TAILGATE DESIGN An aluminium tailgate with integrated spoiler not only contributes to the aerodynamic quality, it also gives the pickup a seamless, unbreakable appearance. Additional tailgate advantages: the "Tailgate-ajar" notification system alerts you if the tailgate isn't completely closed, while damping and key fob control make opening the tailgate a breeze.

RAM 1500: INSPIRED STORAGE SOLUTIONS.



RAMBOX® CARGO MANAGEMENT SYSTEM.

This truck is all about discovering smarter storage solutions and the Ram-exclusive RamBox® defies convention. The RamBox® System has versatile, illuminated, weatherproof, lockable and drainable storage bins. Where it all ends is where life is good: total convenience, total capability.

ALL-POWERFUL KEY FOB

Remote operation of doors and RamBox® System locks, a tailgate release, lowering the Air Suspension mode and the convenient Remote Start System.



Overseas model shown.



TAKE IT ALL WITH YOU The RamBox® Cargo Management System gives you covered and secure storage while still allowing traditional bed space for the essentials.



FULLY DAMPED / ASSISTED TAILGATE WITH POWER RELEASE Opens more slowly and closes more easily. The power-release lets you open it with the key fob button or via the overhead console.



IN-BED LED LIGHTING The RamBox® side cargo-bed lights let you load anytime, and with no adjustment to the tonneau cover.



MANAGE YOUR CARGO Want to keep certain items of cargo separate? The RamBox® offers a standard bed divider and a cargo rail system with four adjustable tie-down loops.



STEEL DEPLOYABLE BED STEP eases cargo access. It's foot-controlled for use or to tuck it back under the bed and features a slip-resistant rubber coating.



BORN TO HAUL,
THE RAM 1500 BEGINS WITH
A STRONG STRUCTURE.

THE MUSCLE AND MECHANICS OF PURE CAPABILITY.

Think robust and resilient frame with plenty of advanced high-strength steel. Formidable suspension technology. Steel cargo bed. Yeah, load it up. Ram 1500 is built to take it.

LOOK INTO YOUR RAM 1500 LIMITED AND YOU'RE LOOKING AT PURE CAPABILITY.

FOUR-CORNER AIR SUSPENSION

The Active-Level™ Four-Corner Air Suspension System is ideal for towing, featuring the Bed-Lowering Hitch Assist.

SMART FRONT AND REAR SUSPENSIONS

What works: a heavy-duty front stabiliser bar and standard link coil rear suspension.

HEAVY DUTY TOWING

Trailering is part of RAM DNA. Heavy duty towing begins with a standard fit heavy duty tow bar.

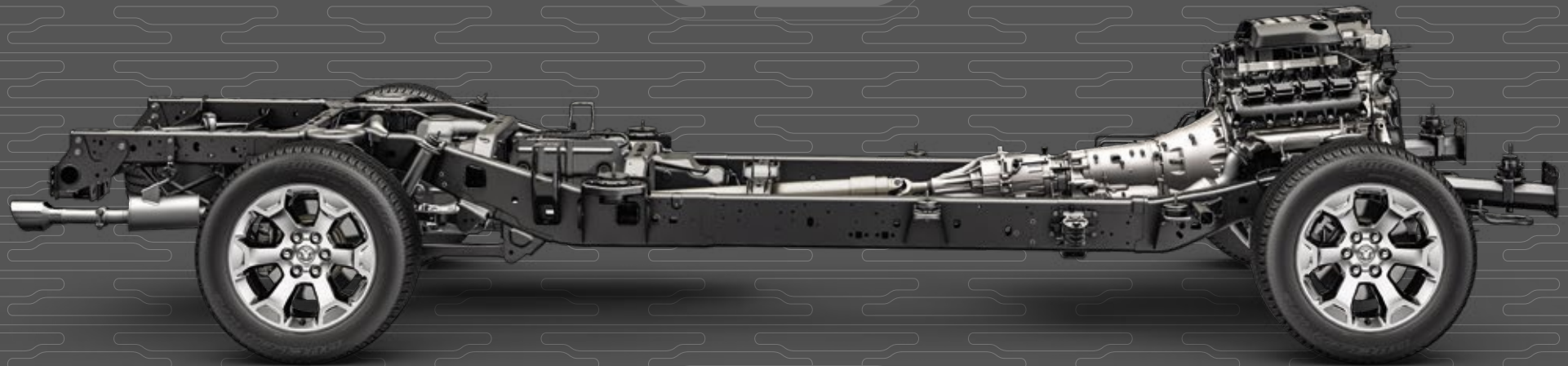

PROGRESSIVE-RATE REAR SPRINGS

They automatically adapt to payload while helping maintain a level profile and superb ride quality.

HIGH-STRENGTH STEEL

The frame takes the concept of durability to extremes. Fully 98 percent of the steel used in the frame is high-strength steel.

SMART SHOCKS

Frequency Response Damping (FRD) shock absorbers adapt to varying surfaces and driver demand.

RIDE STRONG. WITH RAM 1500, IT'S ALWAYS ALL SYSTEMS GO.

From the foundation—a frame in which 98 percent of the steel is high-strength—to the automatic or driver-operated Active-Level™ Four-Corner Air Suspension System, your Ram 1500 is a rolling example of how systems work

together to deliver exceptional performance. Whether it's the tow/haul engineering that enables you to tow big loads or the 8-Speed TorqueFlite® transmission that keeps things running smoothly, this is one pickup ready to work and built to serve.

FROM TOUGH STEEL TO AIR BAGS, SAFETY AND SECURITY ARE AN INTEGRAL PART OF EVERY RAM 1500.

ELECTRONIC PARKING BRAKE

Multifunctional, it features five operational modes, including Safe Mode and Drive-Away Release.

MASSIVE BRAKES

Front and back, these rotors are 378 mm (front) and 375 mm (rear) in diameter.

AIRBAG TECHNOLOGY

It's formidable and includes advanced multistage front airbags, supplemental front-seat side-mounted airbags and side-curtain airbags.

SPLAYED FRAME RAILS

These smartly engineered components direct energy away from the cabin and into the frame rails.



SENSORS, CAMERAS AND TECHNOLOGY

There's still more to Ram 1500 that works to protect you. Details on additional systems are below.

SIDE-IMPACT DOOR BEAMS

Built into every Ram 1500, they reinforce protection against side impacts.

TYRE BLOCKER

Integrated into this frame are tyre blockers—one per side—offering further protection in the event of a frontal crash.

DYNAMIC FRONT CRUMPLE ZONES

A real factor that contributes to safety, they absorb the energy from impact loads.

EXTENSIVE SAFETY AND SECURITY FEATURES.

If you're counting on ample safety and security, count on a Ram 1500 Limited. In addition to the physical strengths listed here are highly sophisticated examples of software, sensors and camera technology.

Indispensable features include: LaneSense® Lane Departure Warning Plus, Adaptive Cruise Control with Stop and Go, Forward Collision Warning with Active Braking, Blind Spot Monitoring, SmartBeam® Intelligent Headlamps, the 360° Surround-View Camera System... and more.



BRILLIANT DETAILS.

THE FINE ART OF DESIGN: TEXTURES, MATERIALS AND PATTERNS.

For sure, towing huge boats and trailers is impressive. But we think it's the details that are impressive. You'll find them everywhere in the Ram 1500 Limited.

KEEPING IT REAL GENUINE RAM ACCESSORIES

Individuality, protection and functionality are the key design pillars when developing a range of accessories for any vehicle. The fitment of genuine Mopar Accessories will individualise the look of your Ram Truck, while, at the same time, features such as bonnet protectors or weather shields provide interior and exterior surface protection to ensure your truck stays in top condition.

Each Ram Truck owner has unique requirements and expectations of their vehicle which is why we have developed a range of genuine Mopar Accessories. So, to find out how you can add to the functionality of your Ram Truck, or for further information on our range of Accessories, contact your local authorised Ram Truck dealer today.



*Warranty terms, conditions and exclusions apply.

THE RAM COLLECTION

Check out the Ram Collection for a range of Ram branded goodies across apparel, camping goods, drinkware and more!

To keep our range fresh, we're updating products from time to time*. To see our current range visit:

<https://merchandise.ramtrucks.com.au/>

*Images shown are for illustration purposes only.



RAM LIMITED EXTERIOR



White (P)



Billet Silver (M)



Granite Crystal (M)



Diamond Black (P)

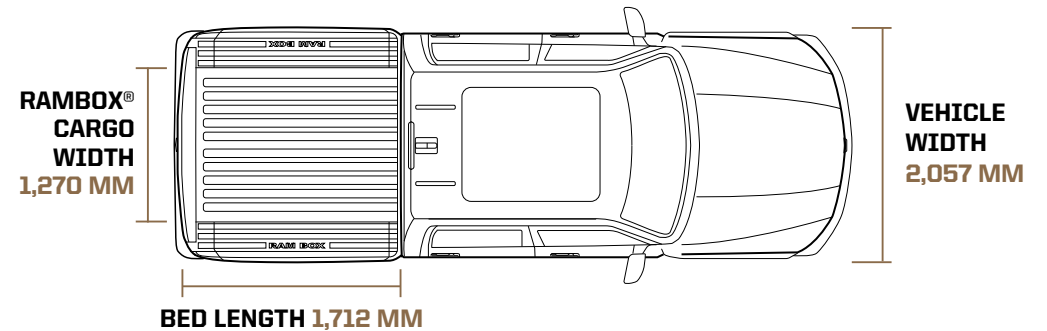
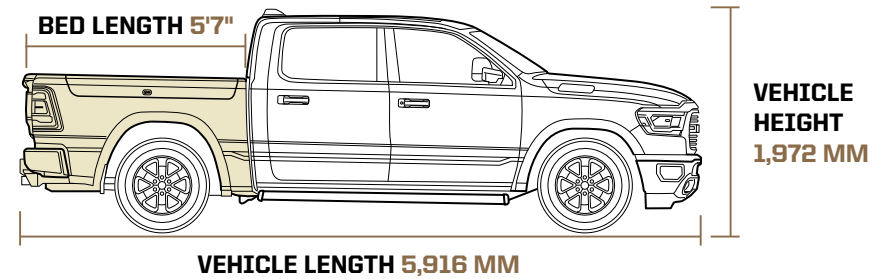

M = Metallic, P = Pearlescent. Colours have been reproduced as faithfully as possible, however actual colours may vary due to screen settings.

RAM TRUCKS NZ AND AUSTRALIA

Is the only Ram authorised provider of proven right-hand-drive trucks in the world. Our trucks are built in Australia by Aussies and Kiwis. No-one can match our factory-backed, OEM-quality product, value and national dealer networks for peace of mind.



Ram Trucks NZ and Australia = 26% of export market Ram sales (2020)



Strong dealer networks across New Zealand and Australia



No.1 market outside of North America (2020)



UNRIVALLED EVERYDAY[®]



RAM

EATS UTES FOR BREAKFAST[®]

RAMTRUCKS.CO.NZ

GET A QUOTE

BOOK A TEST DRIVE

FIND A DEALER

JOIN OUR COMMUNITY:



@RamTrucksNZ



#RamTrucksNZ



RamTrucksNZ

All the information in this document is accurate at the time of publication however variations and discrepancies may occur from time to time and American Special Vehicles Pty Ltd (trading as Ram Trucks Australia) insofar as is permitted by law to do so shall not be liable in any way as a result of any reliance by any person on anything contained in this document. RAM, HEMI, the Ram's Head Logo, Ram 1500 Express, RamBox, AllSecure, ActiveAir, Active-Level, Laramie, LaneSense, ParkSense, ParkView, TorqueFlite, RAM Rebel and Uconnect are registered trademarks and Keyless Enter 'n' Go are trademarks of FCA US LLC, used with permission. Eats Utes For Breakfast, and Unrivalled Everyday are registered trademarks of American Special Vehicles Pty Ltd. Bilstein is a registered trademark of August-Bilstein GmbH & Co. Bluetooth is a registered trademark of Bluetooth SIG, Inc. SmartBeam is a registered trademark of Gentex Corporation. Apple CarPlay, Apple Maps, Apple Music, iPhone and Siri are registered trademarks of Apple Inc. Apple CarPlay® connectivity requires compatible iOS device. See apple.com.au for more details. Google, Google Maps, Google Play, Android, Android Auto, YouTube Music and Waze are trademarks of Google LLC. Android Auto™ connectivity requires compatible Android device. See android.com/intl/en_au/ for more details. Audible is a registered trademark of Audible Inc. Spotify is a registered trademark of Spotify AB. WhatsApp is a registered trademark of WhatsApp Inc. Ram Trucks Australia is the only RAM-authorized right-hand-drive manufacturer and distributor of Ram Trucks in Australia. Overseas models may be shown. Some features and accessories shown are not standard and are at additional cost. This publication is dated December 2021. Ram Trucks Australia reserves the right to discontinue models at any time or change specifications without notice or without incurring obligation. Please consult with your authorised Ram Truck dealer for any rolling specification changes that may occur from time to time. All texts, pictures and other works published herein are subject to the copyright of FCA US LLC or Ram Trucks Australia, if not otherwise indicated. Any duplication, distribution, storage, communication, broadcast and reproduction or transmission of the contents without written approval from FCA US LLC and Ram Trucks Australia is prohibited. Ram 1500 Limited NZ_2021_002.