

 **XCMG** SALES
& SERVICE

GR1003

MOTOR GRADER



www.xcmgmachinery.com.au

INDUSTRY EXPERTISE

XCMG Sales & Service is one of Australia's **fastest growing** construction and mining equipment suppliers.

Offering premium quality excavators, wheel loaders, compaction rollers, graders, access equipment and mini excavators, XCMG Sales & Service has **the products and the support** to keep you working on any job site.

MACHINERY SALES

XCMG Sales & Service know construction and mining equipment. You can count on our **dedicated and knowledgeable team** of product experts to take the time to understand and satisfy your machinery needs by recommending the **right solution for the job**.

RENTALS & HIRE

If you need a high-performance machine with reliability you can **trust**, and the flexibility of hiring, we have you covered.

Our fleet is diverse, with machines to suit almost any job. Furthermore, because our rental fleet is maintained by factory-trained technicians, you can be confident that you'll not only be getting the best machines on the market, but that it's going to **work as hard as you do**, day-in day-out.

AFTERMARKET SUPPORT

We're here to help keep you and your machine working. With an **exceptional over-the-counter fill rate** on spare parts, you're assured that when you buy a machine from XCMG Sales & Service, you'll be looked after throughout your machine's entire lifetime, from start to finish.

Every service job is as important to us as it is to you, and with a dedicated team of machinery technicians, we have ample resources to look after any of your machine repairs or servicing requirements **quickly and efficiently**.

ABOUT

The World's 3rd largest manufacturer of construction and mining equipment.

Founded in 1943, 8 decades of experience.

Manufacturing in USA, Germany, China, Brazil and India.

Extensive supply chain and dealer network throughout Australia.

Deep relationships with corporate giants: Rio Tinto, BHP and MMG in Australia.

MINI / LARGE EXCAVATORS

1 to 49 Tonne

WHEEL LOADERS

5 to 100 Tonne

COMPACTION ROLLERS

1.5 to 30 Tonne Smooth & Padfoot

GRADERS

7.5 to 70 Tonne

ACCESS EQUIPMENT

Lift Heights from 5 to 21 Metres



NEWCASTLE (NORTHERN NSW)

Situated in Hexham on the Pacific Highway. Serves the Northern NSW region from the Hawkesbury River to the QLD border. Company headquarters: complete sales, service (in-house / field), hire, parts and corporate shared services.

PERTH (WESTERN AUSTRALIA)

Located in Welshpool just 15 minutes from the CBD, serves the entire state of Western Australia. Sales, rentals, parts and service, including field service capabilities to various mine sites throughout WA.

BRISBANE (QUEENSLAND)

Situated 30 minutes from the CBD, conveniently located to serve all areas of Queensland. Sales, rentals, parts and service (in-house and field).

Yellow: Branch Location
Blue: Sales Territory
Grey: National Service Agents

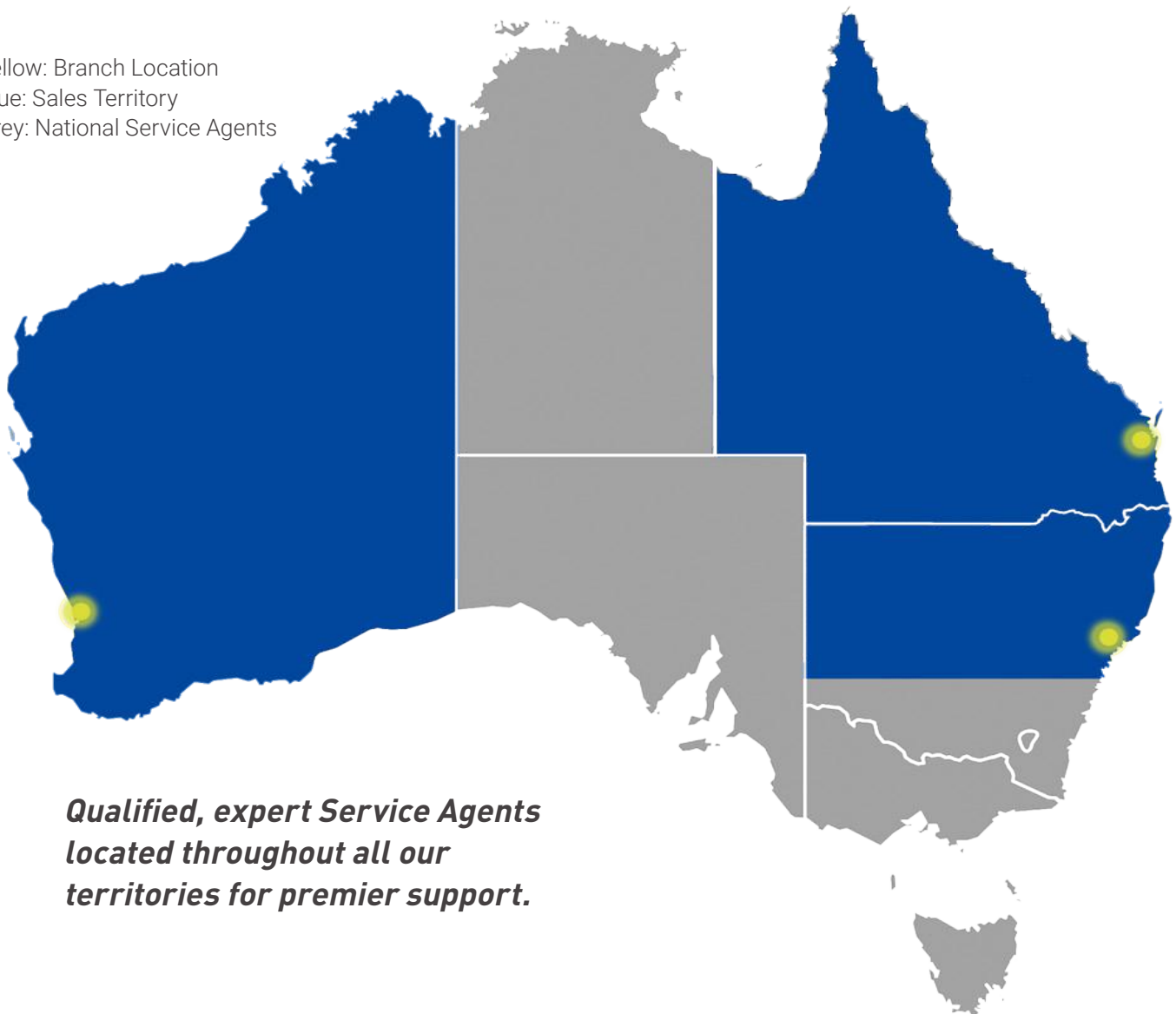

***Qualified, expert Service Agents
located throughout all our
territories for premier support.***

PERFORMANCE, RELIABILITY VALUE

CUMMINS ENGINE

The GR1003 is fitted with a Cummins QSB3.9 4-cylinders engine and is equipped with electrically control high-pressure common rail, turbocharger



GROUND LEVEL ACCESS

Daily checks are efficient thanks to easily accessible service and maintenance components, including re-fuelling, fluid checks and air filters.

EASY SERVICE ACCESS

All daily maintenance points are easily reached and serviced from the ground, ensuring simple day-to-day checks for the operator.

Designed to perform...



GR1003 MOTOR GRADER

SAFE AND RELIABLE

Full hydraulic braking system, load sensing steering, and optimised control structure reducing operating force by up to 30%.

DUAL CIRCUIT ISOLATORS

Dual circuit isolators provide more flexibility for operators and/or repair personnel when performing service and maintenance operations - improving the overall safety of the machine.

DUAL EMERGENCY STOPS

E-stops are located inside the cab as well as outside to the rear of the machine to ensure easy access to shut down the machine in case of an emergency.

STEERING WHEEL

The ergonomically-designed steering wheel reduces operator fatigue and is full adjustable to suit all operators.

EFFICIENT OPERATION

The GR1003 offers a remarkably comfortable, flexible and ergonomic control system, engineered for smooth and efficient operation.

MANOEUVRABILITY

The single oil cylinder, large steering angle, and front axle are all XCMG patented technologies, which combined with an articulated frame and small turning radius, ensure greater manoeuvr.

REVERSING CAMERA STANDARD

A high resolution 10" LCD Screen gives the operator a commanding view of the rear of the machine while reversing.

BLADE DESIGN

The optimised blade shape works quickly and efficiently, whilst creating optimal load distribution and minimal material accumulation within the rotary disc area.



...built to last.



Ergonomic operator control system



Reverse camera and rear work lights



Air conditioned cabin with temperature control



GR1003 MOTOR GRADER



GR1003 SPECIFICATIONS

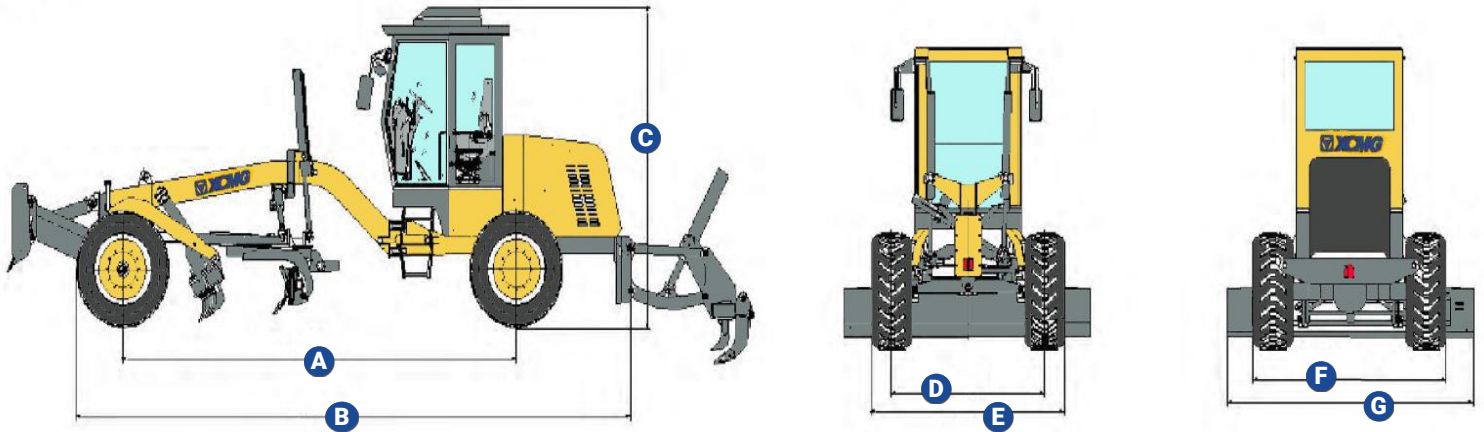

| GR1003 | A | B | C | D | E | F | G |
|--------|------|------|------|------|------|------|------|
| mm | 5135 | 7130 | 3150 | 1900 | 2375 | 2375 | 3048 |

KEY PERFORMANCE SPECIFICATIONS

| | | |
|---------------------|------------------------------------|---------------------------|
| Key Specs | Engine Model: | QSB 3.9 |
| | Rated Power/Speed: | 81/2200 kW/rpm |
| | Overall Dimension: | 7130 x 2375 x 3150 |
| | Total Weight: | 7500 kg |
| | Tyre Specification: | 16/70 - 24/13 - 24 |
| | Ground Clearance: | 550 mm |
| | Tread: | 1900 mm |
| | Front and Rear Axles: | 5135 mm |
| | Coolant: | 50 L |
| | Fuel Tank: | 260 L |
| | Engine: | 18 L |
| | Transmission: | 26 L |
| | Drive Axle: | 28 L |
| Hydraulic Oil: | 89 L | |
| Performance | Forward Speed (6 Speed): | 5, 8, 11, 17, 24, 38 km/h |
| | Reverse Speed (3 Speed): | 5, 11, 24 km/h |
| | Tractive Effort (f=0.75): | ≥ 39 kN |
| | Max Gradeability: | ≥ 25 % |
| | Pressure of Tyres: | 300 kPa |
| | Working System Pressure: | 16 MPa |
| | Transmission Pressure: | 1.3 - 1.8 Mpa |
| Blade | Max Lifting Height: | 310 mm |
| | Max Shoveling Depth: | 350 mm |
| | Max Lateral Inclination Angle: | 45 ° |
| | Cutting Angle: | 28 - 70 ° |
| | Slewing Angle: | 120 ° |
| | Length x Chord height: | 3048 x 450 mm |
| Additional Specs | Max Steering Angle - Front Wheels: | ±49 ° |
| | Max Inclination - Front Wheels: | ±17 ° |
| | Max Swing Angle - Front Axle: | ±15 ° |
| | Max Swing Angle - Balance Box: | ±16 ° |
| | Max Steering Angle - Frame: | ±27 ° |
| Min Turning Radius: | 6 m | |

Note: specifications listed above are correct at March 2022 and are subject to change any time. For additional information visit www.xcmgmachinery.com.au.