

G-SERIES WHEEL LOADERS
1021G | 1121G
STAGE IV

CASE
CONSTRUCTION



MOVING
MOUNTAINS

www.casece.com
EXPERTS FOR THE REAL WORLD
SINCE 1842

G-SERIES WHEEL LOADERS



EXPERTS FOR THE REAL WORLD SINCE 1842

- 1842** **CASE is founded.**
- 1869** **The first CASE portable steam engine - road construction is born!**
- 1958** **The first CASE 4-WD wheel loader, the W9, is introduced.**
- 1969** **CASE begins skid steer loader production.**
- 1998** **Ride control on loader backhoes and skid steer loaders; another CASE first. From 1998 CASE Wheel Loaders run FPT engines, leaders in industrial engine technology.**
- 2001** **The exclusive mid-mounted Cooling Cube in CASE wheel loaders means clean engine, reliability and massive bucket payloads.**

HERITAGE

A TRADITION OF INDUSTRY FIRSTS



- 2011** **CASE is the first in the industry to launch a 5-speed lock up transmission**
- 2012** **CASE completes its EU Stage IIIB wheel loader range: a further step forward in emissions reduction and once again the first in the industry.**
- 2015** **CASE wheel loaders achieve EU Stage IV emissions standards while further increasing fuel efficiency without a DPF**
- 2017** **New G series wheel loaders are launched**
- 2019** **CASE begins introducing Stage V models in Europe, still without traditional DPF. CASE shows, for the first time ever in the industry, the concept of a Compressed Natural Gas (CNG) wheel loader: ProjectTETRA.**

G-SERIES WHEEL LOADERS



HIGH EFFICIENCY

With no EGR or particulate filter

The engine was developed and manufactured by our award winning sister company FPT Industrial, which produces over 500,000 engines per year and powers world record winners.

The in-house design leverages advanced technologies developed for commercial vehicles and agriculture, and introduces specific tailored solutions for off-road applications.

The Cursor 9, with 6 in-line cylinders and an 8.7 litre displacement, is designed to deliver both fuel efficiency and reliability with plenty of power available.

- The air intake flow is increased by a turbocharger with air-to-air cooling.
- The multiple injection delivers best-in-class high torque performance at low rpms.
- No EGR valve is used: 100% fresh air is used for combustion, there is no DPF, and no extra cooling system is needed.

Our engine technology is so reliable that it is trusted by the French Sea Rescue service for their boats: what better guarantee could you wish for?



ENGINE KEEP IT SIMPLE



LOW EMISSIONS Without particulate filter

With HI-eSCR after-treatment, FPT technology meets EU Stage IV emissions standards, a big step towards cleaner air. With this system, fewer components are involved, engine oil quality is not compromised and there is no need for a particulate filter (DPF) or

additional cooling. This allows for a very compact engine compartment, resulting in excellent rear visibility. In addition, the maximum temperature reached by HI-eSCR is 500°C, 200°C below the maximum temperature of a particulate filter.



1996: EU Stage I

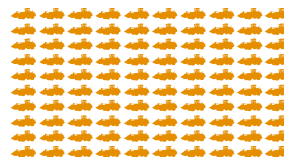

2011: EU Stage III B

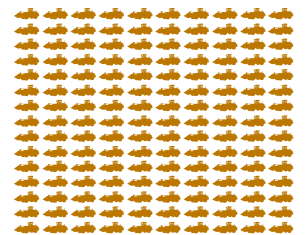

2015: EU Stage IV

HI-eSCR

It would take six months for a Stage IV wheel loader with HI-eSCR technology to produce the particulate and NOx emissions that a Stage I wheel loader would produce in one day.

G-SERIES WHEEL LOADERS

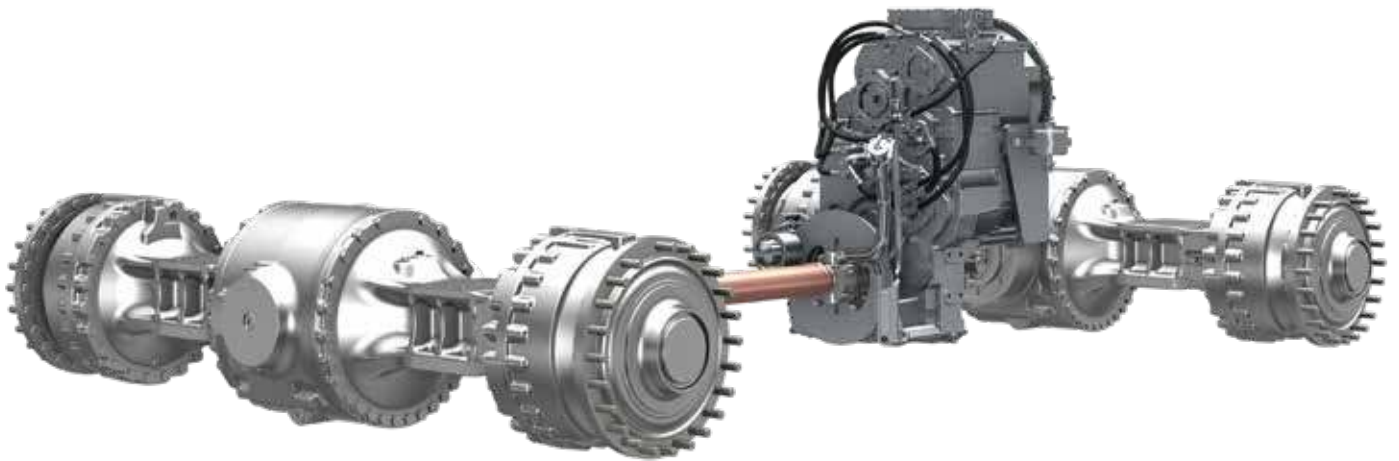

HIGH RELIABILITY

Heavy-duty axles

The heavy-duty axles are tougher, bigger and easier to service thanks to the 3-piece housing design. Wet multiple disc brakes, made of resistant sintered bronze, are located in each wheel hub. Our heavy-duty axles are engineered to support L5 or solid tyres for very abrasive environments.

Metal face seals positioned between axle and hub are resistant to water and fine debris at low temperatures. The heavy-duty axles on 1021G and 1121G are also available with optional oil cooling.

The heavy-duty axles deliver added value resulting from:

- 20-30% lower tyre wear because of no slippage between the wheels.
- reduced fuel consumption because there is no friction in the differential.
- reduced downtime for maintenance because of fewer moving components with open differentials.



AXLES AND DIFFERENTIALS WHEN EFFICIENCY MEETS PRODUCTIVITY



COST SAVINGS

100% auto-lock differential

With open differentials, no friction is applied to reduce wheel slip. As a result, there is less tyre wear and lower energy losses. With the 100% auto-lock, 100% of the available torque is transmitted to the wheels to provide maximum tractive effort.



Loading on soft ground		Taking a curve on solid ground	
<p>With limited slip differential:</p> <ul style="list-style-type: none"> - 70% tractive effort transmitted to the wheels - Automatic engagement 	<p>With 100% diff lock (optional):</p> <ul style="list-style-type: none"> - 100% tractive effort transmitted to the wheels - Automatic or manual engagement 	<p>With limited slip differential:</p> <ul style="list-style-type: none"> Automatic slip limited engagement - Internal losses and wind up - Increased tyre wear 	<p>With 100% diff lock (optional):</p> <ul style="list-style-type: none"> No engagement (open diff) - No energy loss - Less tyre wear

G-SERIES WHEEL LOADERS



HIGH RELIABILITY

CASE cooling cube

The unique design of the CASE cooling cube, with five radiators mounted to form a cube instead of overlapping, ensures a constant flow of fresh and clean air from the sides and from the top to maintain constant fluid temperatures.

The cube structure provides easy access to radiators for a more effective cleaning and improved serviceability: additional cleaning can also be easily done manually, with separate access to each radiator.

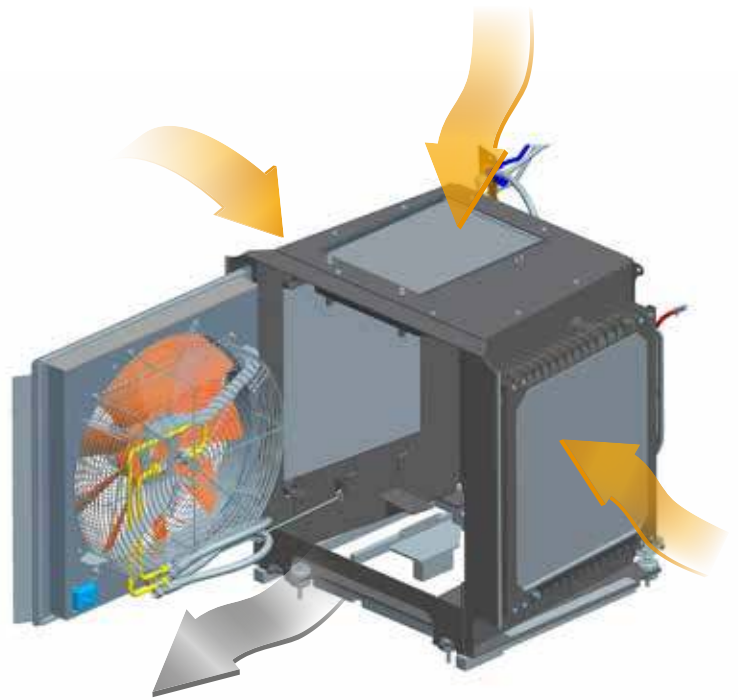

CASE COOLING CUBE DETAILS

1. Variable speed reversible fan
2. Hydraulic oil cooler
3. Transmission oil cooler
4. Turbo air intercooler
5. A/C condensator
6. Diesel radiator
7. Engine radiator

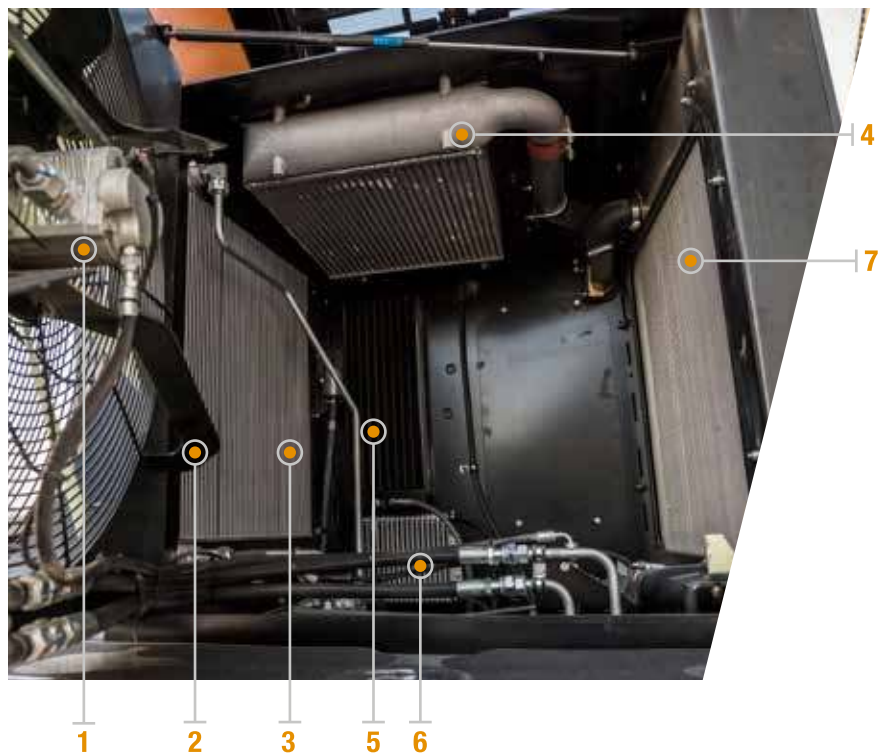

CASE COOLING CUBE ENGINE BREATHES DUST-FREE AIR



LESS MAINTENANCE

CASE cooling cube

- In dusty environments like sand pits or quarries the cleaning of the radiators can be very time consuming: this is not the case with the cooling cube.
- The constant temperature of the fluid maximises its cooling performance and protects the axles, resulting in greater reliability. This is further enhanced by the easy maintenance and longer service intervals.



HIGH RELIABILITY

Air filter dust ejector

All 1021G and 1121G wheel loaders are fitted with an air filter dust ejector: the low pressure in the exhaust is used as a vacuum cleaner to remove the dust stuck in the air intake filter. This system is designed to improve your machine performance in terms of reliability, especially in dusty environments.



G-SERIES WHEEL LOADERS



NEW CAB

THE ULTIMATE COMFORT



HIGH VISIBILITY

Front visibility

- The one-piece design windshield provides an unobstructed panoramic view.

Rear Visibility

- Multiple rear view convex mirrors, a rear view display, the slim engine hood and rear grid defroster ensure optimum rear visibility.

Night Visibility

- LED lighting is so effective that you won't see any difference between night and day work.



OPERATOR PROTECTION

Noise and vibration

- The new active suspension premium seat features electronic auto-weight adjustment, a dynamic dampening system and a low frequency shock absorption system. Combined with the suspended cab mount this reduces the noise and vibrations the operator is subjected to.
- Noise in the cab is not only low (69 dB): it also sounds great.

Cab air

- Primary and recirculation filtration efficiency now reaches 99% of particles with improved dust capacity and longer replacement intervals. When working in particularly tough conditions, additional active carbon filters can be fitted.

Cab access

- Access is easier and safer thanks to the optimised handrails and the pull-type handle.



OPERATING COMFORT

Seat and controls

- The seat mounted armrest gives more accurate control and comfort. It features 3rd/4th function proportional control integrated in the joystick, as well as the option of replacing the joystick with two or three (for the 3rd function) fingertip levers.
- New joystick steering: the operator handles two equally sized joysticks, just like on an excavator, which reduces fatigue. It features speed proportional sensitivity and slow/medium/fast settings.
- The suspended seat includes seat heaters which warm it up in the cold winter mornings.

User interface

- The premium control interface with 8" color display offers intuitive navigation through the machine's information and settings.
- The hands free calling kit features an integrated microphone connected to the radio via Bluetooth.

Life on board

- The CASE electrically powered cool box keeps your lunch fresh all day long.
- Multiple storage areas enable you to store documents, beverages and personal objects conveniently.

MAINTENANCE HAS NEVER BEEN SO EASY AND FAST



SAFE AND EASY MAINTENANCE

Ground level serviceability

- One-piece electric hood
The easy-to-open electric hood provide fast access to the service points. Jumper cables are available as standard for jump starting the engine if the battery is low.
- Easy daily checks
You can do a fast visual check of the fluids from ground level.
- Greater safety
All the main service points and filters are easily accessible at ground level, so you can carry out your daily maintenance safely and efficiently.



Fuel filter and engine oil service points are easily accessible from both sides while the others filters are behind the right stairs



The air filter is easy to remove and the dust is aspirated and ejected in the exhaust



Remote jump start



OPTIMISED FRONT LOADER DESIGN AND PRODUCTIVITY



MORE PRODUCTIVITY

Linkage and bucket design

- The combined action of the higher engine power, the linkage design and the short bottom bucket provides in a massive 244 kN breakout force in the pile
- The new loader design with high roll back increases the bucket capacity by about 10%. It also significantly improves material retention in carry phases.
- The superior dump angle allows for easy bucket shaking even with sticky material.

The bucket fills faster with the greater thrust and breakout force. The greater bucket capacity and better material retention mean a more effective use of your resources!

MAIN REASONS TO CHOOSE THE G-SERIES



OPERATOR PROTECTION

- Viscous cab suspension
- Pressurized cab with high efficiency filtration
- Low noise (69 dB) and vibration



BEST-IN-CLASS VISIBILITY

- One-piece design windshield, high-efficiency lighting, convex rear mirrors and rear view camera provide optimum visibility 24 hours a day



FAST CYCLES

- Best-in-class breakout force
- Simultaneous lift and tilt at constant lift speed
- Faster bucket lifting allows for faster truck loading



SAFE AND EASY MAINTENANCE

Grouped drains rationalise maintenance operations.



SUPERIOR COMFORT

- Seat mounted console
- Premium control interface with 8" display
- Hands-free calling kit
- Multiple storage areas
- Active suspension premium seat



HIGH RELIABILITY

- Heavy-duty axles
- 100% differential lock
- Unique cooling package
- Best-in-class cooling system with cubic layout
- Optimized engine air filtration



HIGH EFFICIENCY

- With Hi-eSCR you have plenty of power with excellent fuel efficiency

TELEMATICS ANTICIPATION AND CONTROL



THE SCIENCE BIT

The CASE SiteWatch telematics system uses a high-tech control unit mounted on each machine to collate information from that machine and from GPS satellites. This data is then sent wirelessly through the mobile communication networks to the CASE Telematics Web Portal.



SiteWatch: centralised fleet control benefits at your fingertips

Measure your true asset availability and optimise it

- Eliminate the “phantom fleet”: SiteWatch allows to identify spare units or under loaded machines on each site.
- Become able to reallocate units where they are more needed.
- Forward maintenance planning is easier since the actualised working hours are always available.
- Extend the benefits of SiteWatch to the rest of your fleet: SiteWatch can be installed on the units of other brands as well.

Challenge your Total Cost of Ownership!

- Being able to compare the fuel usage of different machine types will allow you choose the right equipment.
- Save on transport costs with planned and grouped maintenance tasks.
- Peace of mind, optimised uptime and lower repair costs: with preventive maintenance you can for example be alerted if the engine needs to be serviced and avoid a disruptive breakdown.
- Be able to compare your asset Return on Investment on different sites.
- Your equipment is used only during working hours. You can set up alerts so that you know if it is in use during the weekend or at night.
- Integrate with the programmed maintenance package, so that you can be sure every machine is at the right place at the right time.

More safety, lower insurance premium

- Keep thieves away: dissuade them from attacking your asset because it is geo-localised. SiteWatch is hidden so that thieves can't find it quickly.
- Your fleet is used only where you decide. You can define a virtual fence and receive an email when a machine exits that perimeter.

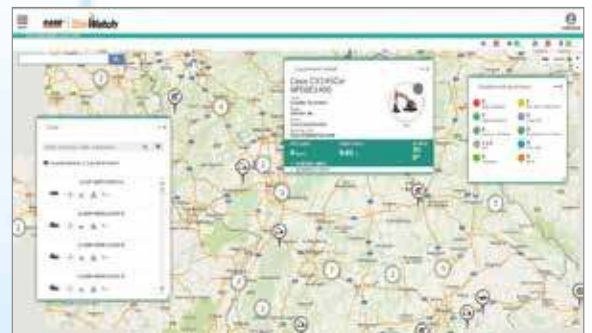

G-SERIES WHEEL LOADERS

SPECIFICATIONS

ENGINE

	1021G	1121G
FPT engine _____	Cursor 9	
Cylinders _____	6	
Displacement (l) _____	8.7	
Air intake _____	Turbocharger with air-to-air cooling. No EGR valve is used: Only fresh air is taken for combustion and no extra cooling system is needed.	
Injection _____	Common Rail Multiple Injection.	
After Treatment System _____	HI-eSCR (DOC + SCR).	
Emission level _____	Compliant with EU Stage IV	
Max. power (kW/hp) _____	239 / 320	259 / 347
(@ rpm) _____	1800	1800
(ISO 14396)		
Max. torque (Nm) _____	1479	1604
(@ rpm) _____	1100	1100
(ISO 14396)		

TRANSMISSION

4-Speed Powershift
4x3 transmission with auto-shift system and Intelligent Clutch Cut Off (ICCO).

	1021G	1121G
Forward 1 (km/h) _____	7	7
Forward 2 (km/h) _____	13	12
Forward 3 (km/h) _____	19	18
Forward 4 (km/h) _____	38	38
Reverse 1 (km/h) _____	7	7
Reverse 2 (km/h) _____	13	13
Reverse 3 (km/h) _____	27	26

AXLES AND DIFFERENTIAL

Rear axle total oscillation _____	24°
Heavy-duty ZF axles _____	with open differentials and automatic 100% lock system on the front differential. Also available with oil cooler. 100% tractive effort always, no wheel slip, less tire wear.

TYRES

Tyres _____	26.5R25	26.5R25
-------------	---------	---------

BRAKES

Service brake _____	Maintenance free, self-adjusting wet 4-wheel disc brakes.	
Brake disc area (m ² /hub) _____	0.74	0.74
Parking brake _____	With the negative brake all four wheels are automatically stopped when the engine is stopped.	
Parking disc brake area (cm ²) _____	82	82

HYDRAULICS

	1021G	1121G
Valves _____	Rexroth Closed-center, Load sensing hydraulic system. Main valve with 3 sections.	
Steering _____	The steering orbitrol hydraulically is actuated with priority valve.	
Automatic functions _____	Bucket Return-to-dig, Boom Return-to-travel, Boom Auto-lift.	
Control type _____	Pilot control with single joystick or two/three levers.	
Type of pump _____	Tandem variable displacement pump.	
(l/min) _____	348	376
(@ rpm) _____	2000	2000

AUXILIARY HYDRAULIC CIRCUIT

Max flow (l/min) _____	240	240
Max pressure (bar) _____	249/255	249/255

SERVICE CAPACITIES

Fuel tank (l) _____	459	459
AdBlue tank (l) _____	65	65
Cooling system (l) _____	57	57
Engine oil (l) _____	26	26
Hydraulic oil tank (l) _____	134	134
Total hydraulic system oil (l) _____	250	250
Front and Rear Axles (l) _____	68	68
Transmission oil (l) _____	45	45

CAB PROTECTION

Protection against falling objects (FOPS) _____	ISO EN3449
Protection against roll over (ROPS) _____	ISO EN13510

NOISE AND VIBRATION

In the cab - LpA (dB) _____	69	69
(ISO 6595/6396/3744)		
Outside - LwA (dB) _____	105	104
(SAE J88 SEP80)		
Vibrations _____	Operator 's seat meets the criteria of ISO 7096:2000. The vibrations transmitted do not exceed 0.5 m/s ²	

ELECTRICAL SYSTEM

24V. Batteries 2 x 12V.		
Alternator (A) _____	120	120

G-SERIES WHEEL LOADERS

1021G GENERAL DIMENSIONS

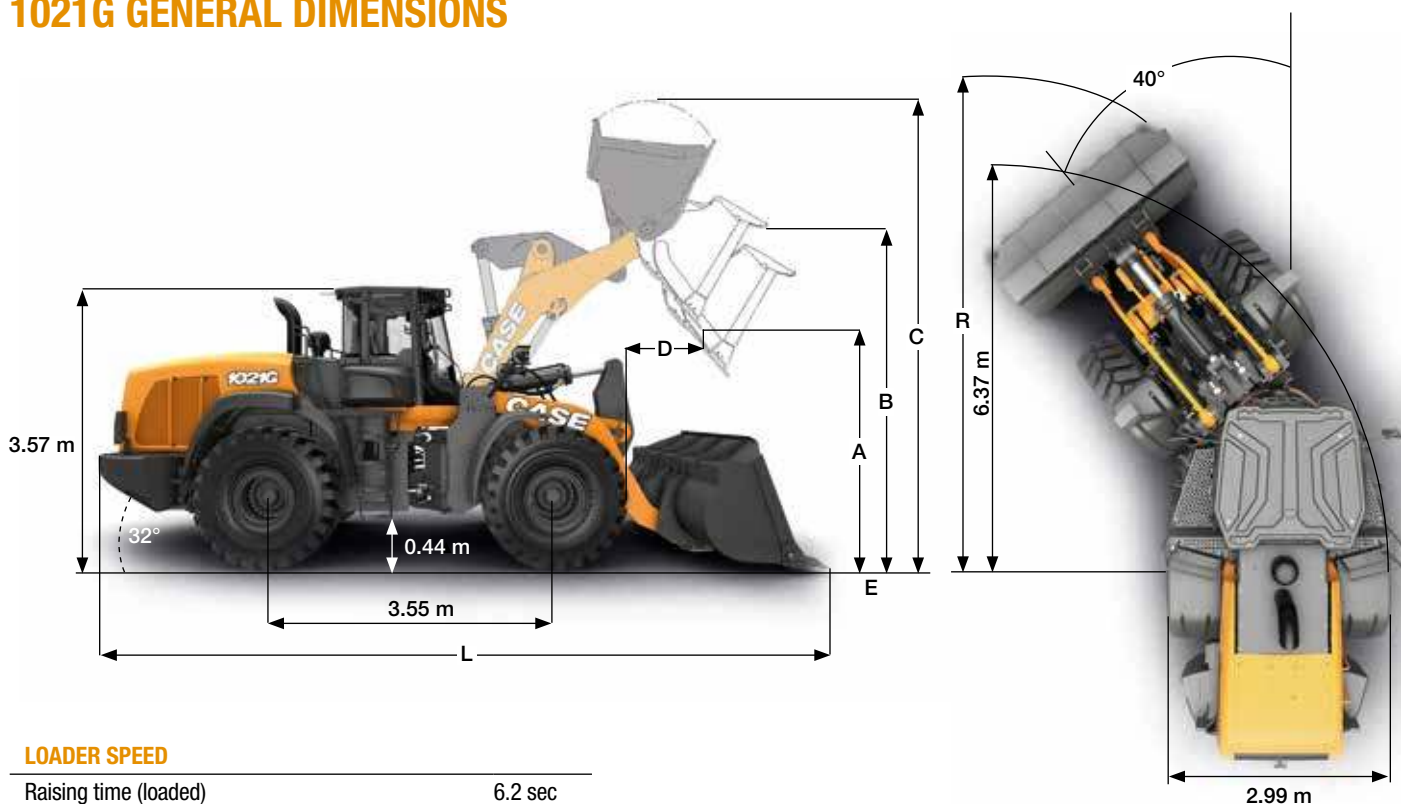

LOADER SPEED

Raising time (loaded)	6.2 sec
Dump time (loaded)	1.3 sec
Lowering time (empty, power down)	2.8 sec
Lowering time (empty, float down)	2.6 sec

1021G		Z-BAR bucket				XR buckets		
		4.4 m ³		4.2 m ³		4.2 m ³		
		Pin-on / flat bottom edge	teeth + segments	Pin-on / round bottom edge	teeth + segments	Pin-on / round bottom edge	teeth + segments	
	Bucket volume (heaped)	m ³	4.4	4.4	4.2	4.2	4.2	4.2
	Bucket volume at 110% filling rate	m ³	4.8	4.8	4.6	4.6	4.6	4.6
	Bucket Payload	ton	9505	9445	9580	9520	7740	7680
	Maximum material density	ton/m ³	2.16	2.15	2.28	2.27	1.84	1.83
	Bucket outside width	m	3.02	3.05	3.17	3.20	3.17	3.20
	Bucket weight	kg	2320	2410	2140	2230	2140	2230
	Tipping load - straight	kg	21890	21770	22040	21910	17970	17840
	Tipping load - Articulated at 40°	kg	19010	18890	19160	19040	15480	15360
	Breakout force	kg	19070	19430	20000	20400	20635	22090
	Lift capacity from ground	kg	23170	23090	23500	23420	18960	19120
A	Dump height at 45° at full height	m	2.94	2.84	3.06	2.96	3.66	3.54
B	Hinge pin height	m	4.25	4.25	4.25	4.25	4.83	4.83
C	Overall height	m	5.96	5.96	5.85	5.85	6.40	6.40
D	Bucket reach at full height	m	1.22	1.29	1.29	1.36	1.28	1.41
E	Dig depth	cm	12	15	12	15	13	13
L	Overall length with bucket on the ground	m	9.03	9.17	8.97	9.11	9.43	9.57
	Overall length without bucket	m	7.55	7.55	7.55	7.55	8.00	8.00
R	Turning radius to front corner of the bucket	m	7.04	7.09	7.09	7.14	7.35	7.42
	Bucket rollback in carry position	°	49°	49°	49°	49°	48°	48°
	Dump angle at full height	°	48°	48°	53°	53°	50°	50°
	Machine operating weight with XHA2 (L3) Tyres	kg	25760	25860	25590	25680	26630	26720
	Machine operating weight with VSDL (L5) Tyres	kg	26964	27064	26794	26884	27834	27924

1121G GENERAL DIMENSIONS

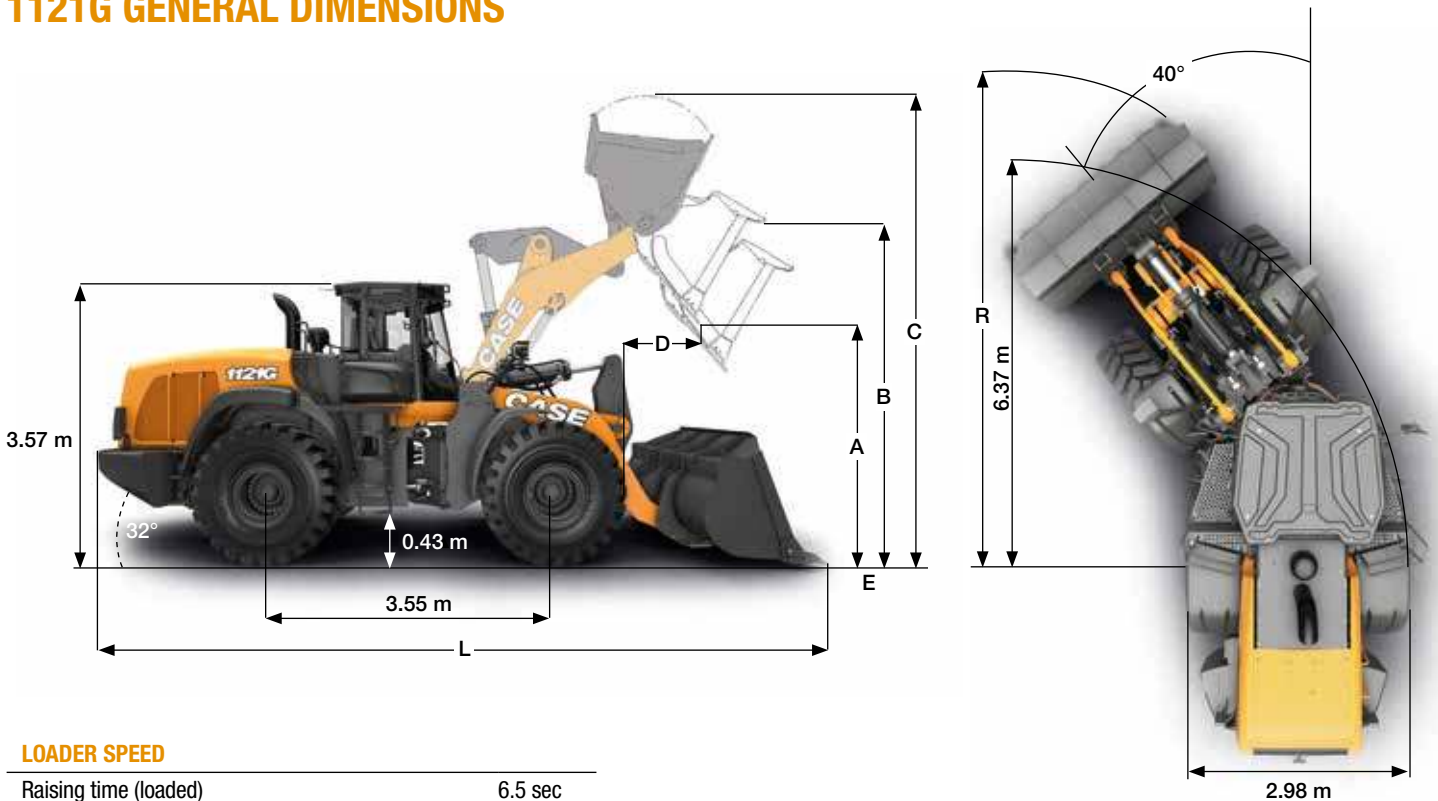

LOADER SPEED

Raising time (loaded)	6.5 sec
Dump time (loaded)	1.4 sec
Lowering time (empty, power down)	2.8 sec
Lowering time (empty, float down)	2.6 sec

1121G		Z-BAR bucket				XR bucket	
		5.0 m ³		4.8 m ³		4.8 m ³	
		Pin-on / flat bottom edge	teeth + segments	Pin-on / round bottom edge	teeth + segments	Pin-on / round bottom edge	teeth + segments
	Bucket volume (heaped)	m ³	5.0	5.0	4.8	4.8	4.8
	Bucket volume at 110% filling rate	m ³	5.5	5.5	5.3	5.3	5.3
	Bucket Payload	ton	10210	10150	10285	10220	8710
	Maximum material density	ton/m ³	2.04	2.03	2.15	2.14	1.82
	Bucket outside width	m	3.18	3.20	3.17	3.20	3.17
	Bucket weight	kg	2450	2540	2250	2340	2250
	Tipping load - straight	kg	23580	23460	23710	23590	20250
	Tipping load - Articulated at 40°	kg	20420	20300	20570	20440	17420
	Breakout force	kg	22330	22750	22210	22630	22210
	Lift capacity from ground	kg	25600	25500	25740	25640	21580
	A Dump height at 45° at full height	m	3.12	3.01	3.19	3.09	3.62
	B Hinge pin height	m	4.45	4.45	4.45	4.45	4.859
	C Overall height	m	6.23	6.23	6.15	6.15	6.537
	D Bucket reach at full height	m	1.17	1.24	1.29	1.37	1.32
	E Dig depth	cm	11	14	11	14	12
	L Overall length with bucket on the ground	m	9.19	9.32	9.20	9.33	9.75
	Overall length without bucket	m	7.70	7.70	7.70	7.70	8.24
	R Turning radius to front corner of the bucket	m	7.17	7.22	7.17	7.22	7.38
	Bucket rollback in carry position	°	49°	49°	49°	49°	48
	Dump angle at full height	°	45°	45°	50°	50°	50°
	Machine operating weight with XHA2 (L3) Tyres	kg	28170	28260	27970	28060	28780
	Machine operating weight with VSDL (L5) Tyres	kg	29374	29464	29174	29264	29984

www.casece.com

EXPERTS FOR THE REAL WORLD
SINCE 1842

CASE
CONSTRUCTION



Form No. 20210GB - MediaCross Firenze - 01/20

**CNH INDUSTRIAL
DEUTSCHLAND GMBH**
Case Baumaschinen
Benzstr. 1-3 - D-74076 Heilbronn
DEUTSCHLAND

CNH INDUSTRIAL FRANCE, S.A.
16-18 Rue des Rochettes
91150 Morigny-Champigny
FRANCE

CASE CONSTRUCTION EQUIPMENT
Cranes Farm Rd
Basildon - SS14 3AD
UNITED KINGDOM

CNH INDUSTRIAL - MIDDLE EAST
DAFZA - Dubai Airport Free Zone
West Wing 4 B, Office 642
P.O. Box 54588, Dubai,
UNITED ARAB EMIRATES

**CNH INDUSTRIAL
MAQUINARIA SPAIN, S.A.**
Avenida Aragón 402
28022 Madrid
ESPAÑA

CNH INDUSTRIAL ITALIA SPA
Strada di Settimo, 323
10099 San Mauro Torinese (TO)
ITALIA

CASE CUSTOMER CENTRE
PARIS
RN 330 - Penchard
77122 - Monthyon
FRANCE

NOTE: Standard and optional fittings can vary according to the demands and specific regulations of each country. The illustrations may include optional rather than standard fittings - consult your Case dealer. Furthermore, CNH Industrial reserves the right to modify machine specifications without incurring any obligation relating to such changes.

Conforms to directive 2006/42/EC

CASE
00800-2273-7373

The call is free from a land line.
Check in advance with your Mobile Operator if you will be charged. Toll free number not available from all calling areas.

