

PAVISE D217

ZF – 9 Speed Manual
ZF – 12 Speed AMT



*Image may contain items not standard to the model

4 x 2 Cab Chassis

KEY FEATURES

Vehicle Dynamic Control (VDC)
Lane Departure Warning System (LDWS)
Forward Collision Avoidance Assist (FCA)
Autonomous Emergency Braking System (AEBS)
Emergency Stop System (ESS)
Electronic Braking System (EBS)
SRS Airbags Driver & Passenger
Cruise Control

KEY SPECIFICATIONS

GVM	17,600Kg
GCM	27,000Kg
Engine	5.9L (EURO 5) 6 Cylinder Turbo
Power	276hp/205kw
Torque	932Nm
Transmission	ZF 9 Speed MT / ZF 12 Speed AMT
Wheelbase	LWB 4.3m, ELWB 4.9m, ULWB 5.7m
Max. Body Length	LWB 5.8m, ELWB 6.8m, ULWB 8.1m

ENGINE

Engine Model	Hyundai D6GA253
Engine Type	Diesel, 5.9L (Euro 5) 6 in-line Cylinder Turbo
Max. Output	276hp/205KW @ 2,500 RPM
Max. Torque	932Nm. @ 1,400 RPM
Max. Engine R.P.M	2,500 RPM
Fuel Injection	Electrical Type by ECU
Cooling System	Auto Clutched Type
Compression Ratio	17.0: 1
Piston Displacement	5,899 cc
Bore and Stroke	103 x 118 (mm)
Valve System	SOHC, 4 Valves per Cylinder
Exhaust	EGR + DOC + PMC
Alternator	24V-70A
Engine Immobilizer	Equipped

TRANSMISSION & GEAR RATIOS

Make & description	Manual Transmission (ZF9S1310T0)		AMT Transmission (ZF12AS1210T0)	
	ZF 9 Speed Manual		ZF 12 Speed AMT	
Gear Ratios	Crawler	9.48	1 / 2	10.37/8.43
	1 / 2	6.58 / 4.68	3 / 4	6.49 / 5.27
	3 / 4	3.48 / 2.62	5 / 6	4.18 / 3.40
	5 / 6	1.89 / 1.35	7 / 8	2.48 / 2.02
	7	1.00	9 / 10	1.55 / 1.26
	8	0.75	11 / 12	1.00 / 0.81
	REVERSE	8.97	REVERSE	10.56 / 8.58
	Gear Shaft	Floor Shift	Mechanical Remote Control	
Rear axle ratio	3.909 / 4.111			

BRAKES

Type	Drum Brakes Front & Rear
Actuation	Drum: Full Air S-CAM Brake with Diaphragm Chamber
Front Drum Diameter X Lining Width	410 x 156 x 16
Rear Drum Diameter X Lining Width	410 x 200 x 18
Adjusted	Auto Adjuster
Vehicle Stability Control (VSC)	Equipped
Auxiliary Brake	Air Operated, butterfly valve
Anti-lock Brake System (ABS)	Equipped
Electronic Braking System (EBS)	Equipped
Traction Control (TC)	Equipped

SAFETY FEATURES

Active Safety Features	
Vehicle Stability Control	VSC (Equipped)
Anti-lock Brake System	ABS (Equipped)
Forward Collision Avoidance Assist	FCA (Equipped)
Emergency Stop System	ESS (Equipped)
SRS Airbag	Driver & Passenger
Electronic Braking System	EBS
Lane Departure Warning System	LDWS
Traction Control	TC
Adaptive Cruise Control	ACC
Easy Start Hill Assist	ES

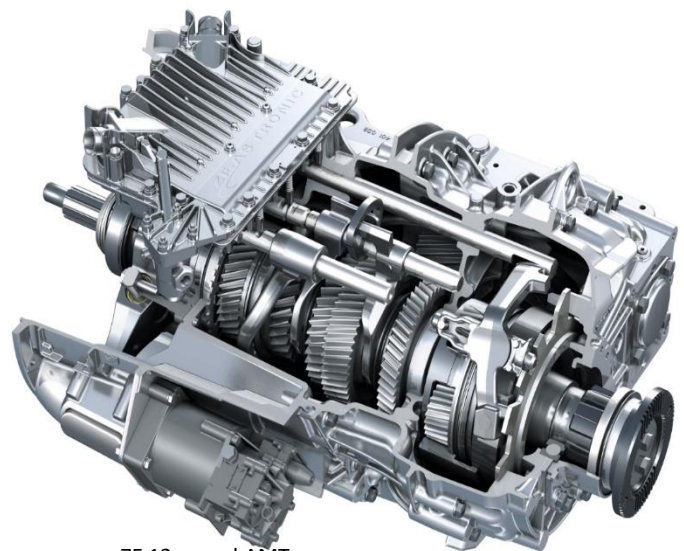

ZF 12-speed AMT

SUSPENSION & LOAD LIMITS

FRONT	Front Axle Type	Reverse Eliot Type "I" Beam		
	Front Axle Capacity	7,500 kg		
	Suspension	Multi Spring Suspension		
	Spring Dimensions	1500 x 80 x 8 Leaves (14t-2, 15t-6)		
REAR	Rear Axle Type	Full Floating Type (R150HS)		
	Rear Axle Capacity	9,500 kg		
	Rear Suspension Types	Leaf		
	Suspension Description	Multi Spring		
	Spring Dimensions	Main	Helper	
	Length & Width (mm)	1300 x 70 x 12 Leaves (14t-4, 13t-2, 12t-5, 11t-1)	900 x 70 x 5 Leaves (13t-3, 12t-2)	

CLUTCH (MANUAL MODELS)

Type	Hydraulic Control (air assisted), Diaphragm Spring. Single Dry plate, Pre- Damper
Facing Size	395 mm (outside diameter) x 240 mm (inside diameter)
Facing Material	Non-Asbestos

WHEELS & TYRES

Wheel Type	Single Front, Double Rear
Wheel	Front, Rear 22.5x8.25
Material	Steel / (Optional) Aluminum
Tyre Size	Front: 295/80R22.5 Rear: 295/80R22.5
Number of Tires	6
Spare Tyre Carrier	Equipped

ELECTRICAL

Type	24V Negative Earth
Battery	24V-70A
Alternator	24V-70A
Starter Type	24V-5.0KW
Interior & Reading Lamps	LED

CHASSIS FRAME

Wheelbase Variants	LWB	ELWB	ULWB
Wheelbase (mm)	4,300	4,900	5,700
Overall Width (mm)	2,400	2,400	2,400
Cab to Rear Axle	3,410	4,010	4,810
Cab to End of Frame	5,320	6,270	7,420
Min. Ground Clearance	305	305	305

PERFORMANCE

Wheelbase	Long	Extra Long	Ultra-Long
Application Engines	D6GA28A	D6GA28A	D6GA28A
Max. Speed (KM/HR)	127.9	127.9	127.9
Max. Gradeability (tan0)	0.322	0.322	0.322

FUEL TANK

Material (L) Liter	Standard: 200L (steel) Optional (ELWB & ULWB): 200 L + 200L (Aluminum)
Fuel Capacity (L) Liter	200L (Standard) / 200L + 200L (Optional)
Fuel Cap	Equipped

STEERING

Steering Type	4-Spoke, Ball-nut type, Tilt & Telescopic Steering Column
Steering Gear Ratio	24.9 (Tilting Angle: 18°)
Inside Steering Angle	44°
Outside Steering Angle	34°
Telescopic Stroke (mm)	65 mm

CAB DETAILS

CAB Type	Sleeper CAB
Seating Capacity	3
Seat Belts	3-point Lap Sash for Driver & Passenger
Sun visor & Overhead	High Roof Only (Optional)
Windscreen Wipers	2-Arm Wiper & Washers
Rear View Mirrors	External; Electric; Remote Heated
Grille Color	Black
Cab heater & Air conditioner	Equipped
Floor Covering	Vinyl Type
Central Locking & Keyless	Equipped with Immobilizer
Cab Storage Pockets	Equipped
Power Windows	Equipped
Cup Holders	Equipped



DIMENSIONS – (mm) / WEIGHTS – (kg)

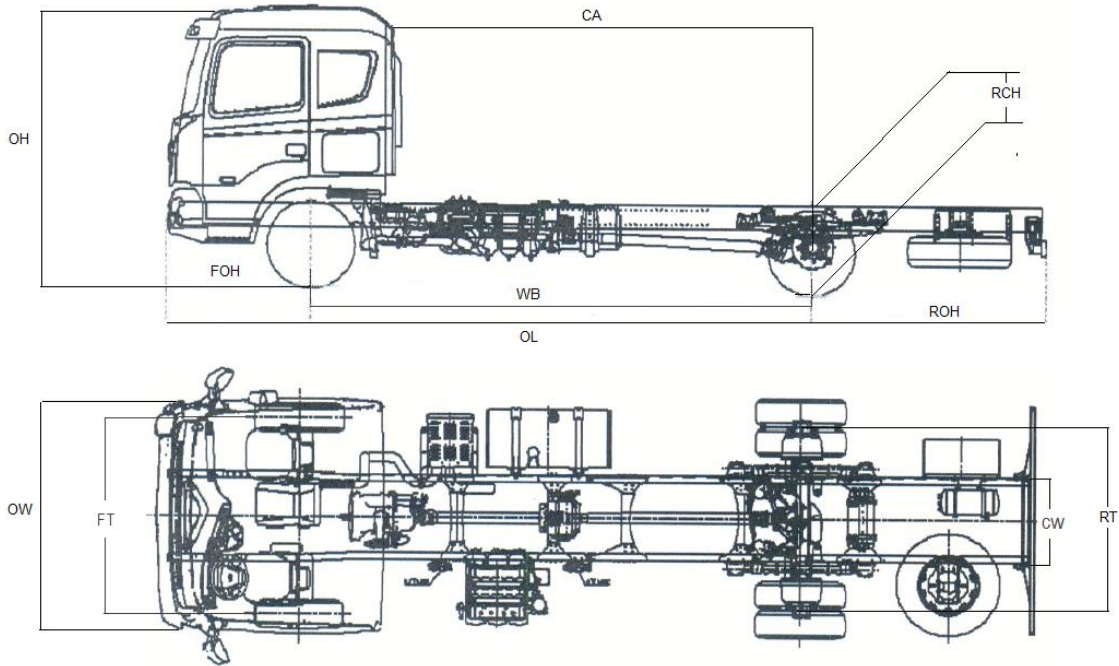

Wheelbase	LWB	ELWB	ULWB
WB	4,300	4,900	5,700
OL	7,665	8,615	9,765
OW	2,400	2,400	2,400
OH	2,735 (High Roof: 2,925)	2,735 (High Roof: 2,925)	2,735 (High Roof: 2,925)
CA	3,410	4,010	4,810
FOH	1,415	1,415	1,415
ROH	1,950	2,300	2,650
RCH	997	997	997
CW	840	840	840
FT	1,978 (Steel) / 1,995 (Aluminum)	1,978 (Steel) / 1,945 (Aluminum)	1,978 (Steel) / 1,945 (Aluminum)
RT	1,800 (Steel) / 1,813 (Aluminum)	1,995 (Steel) / 1,813 (Aluminum)	1,995 (Steel) / 1,813 (Aluminum)
Curb Weight	5,340	5,595	5,750
Front Curb Weight	3,620	3,690	3,805
Rear Curb Weight	1,720	1,905	1,925
Gross Vehicle Weight	17,600	17,600	17,600
Front Axle Capacity	7,100	7,100	7,100
Rear Axle Capacity	10,500	10,500	10,500

HYUNDAI PAVISE WARRANTY

HYUNDAI MEDIUM RANGE	AXLE CONFIGURATION	STANDARD WARRANTY	CAB WARRANTY
PAVISE D217	4 X 2	5 Years or 300,000 KM	5 YEARS

Disclaimer: Hyundai Trucks Australia reserves the right to alter vehicle specifications and equipment levels without notice. Some equipment featured on the vehicle in this brochure may not be available in Australia or may be optional to the extent permitted by the law. Hyundai Trucks Australia shall not be liable to any person as a result of reliance on the content of this document.

Please consult your Hyundai Commercial Vehicle Dealer for the latest specifications, equipment levels, options, prices, colours and vehicle availability. Note: Information in this brochure is current as at 14/05/2021

You're never alone on the road in a Hyundai Pavise series truck. When you're covered by Hyundai's 24/7 nationwide truck roadside assist, you'll never find yourself stranded.

