

bZ4X

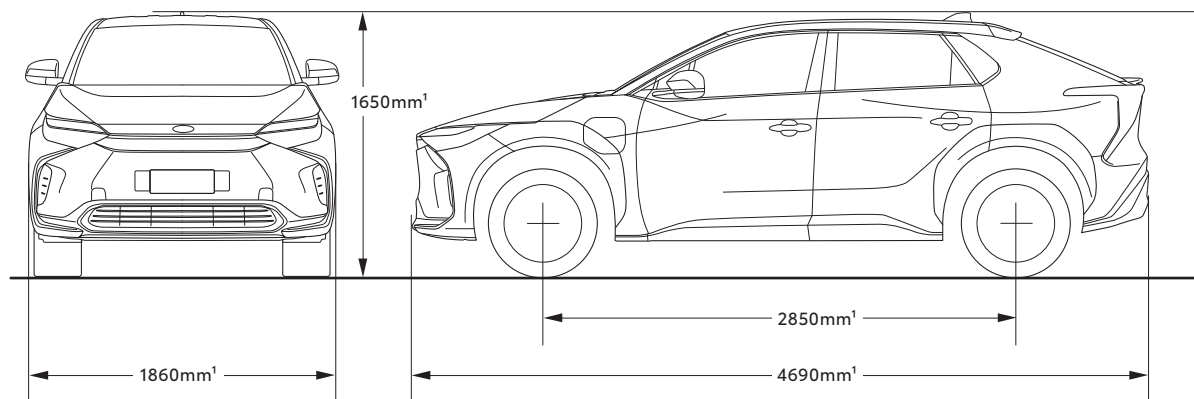

Please Note: information is accurate as at June 2024.

Specification and imagery are indicative and should only be used as a guide. Vehicle and accessory specification, features, colour and trim may differ at the time of vehicle delivery.



MECHANICAL SPECIFICATIONS			bZ4X	bZ4X AWD
ELECTRIC MOTOR	Type		AC synchronous electric generator	
	Maximum(kW)	Front motor	150	80
		Rear motor		80
	Maximum output – system (kW)		150	160
	Model code front/rear (AWD)		1XM / N/A	1YM / 1YM
	Type		Permanent Magnet Synchronous Motor	
	Max torque (Nm)	Front	266.3	168.5
Rear			168.5	
Total		266.3	337	
BATTERY AND CHARGING	Battery type		Lithium-ion battery	
	Battery capacity (Ahr)		201	
	Number of battery cells		96	
	Voltage per cells		3.7	
	Total voltage (V)		355.2	
	Traction battery capacity (Ahr)		201	
	Total power (kWh)		71.4	
	Mode 2 and Mode 3 charging cables		Included	
	AC charging ² – 10-100%		Single-Phase Charging – approx. 9 hours 30 mins / 3-Phase Charging – approx. 7 hours	
	DC charging ^{2,3} – 10-80%		approx. 30 mins	
	AC Input – standard		Type 2	
	DC Input – quick charge		CCS2	
	AC charging power (kw)		11	
	DC charger maximum output (kW)		150	
STEERING	Gear type		Rack & Pinion	
	Type		Electric Power Steering (EPS)	
	Overall gear ratio		14.1	
	Lock to lock		2.81	
SUSPENSION	Front		MacPherson Strut	
	Rear		Double wishbone	
	Stabilizer bar – front and rear		Torsion bar	
BRAKES	Type – front and rear		Ventilated disc brake	
	Front diameter (mm)		328	
	Rear diameter (mm)		317	
	Regenerative braking systems		•	
DRIVETRAIN AND TRANSMISSION	Transaxle model code (Front/Rear)		Q910 / -	Q910 / QA10
	Total speed reduction ratio (Front/Rear)		13.786 / -	13.786 / 13.786
	Front wheel drive		•	
	All wheel drive			•
	Type		BEV automatic transmission	
WEIGHTS AND CAPACITIES (APPROXIMATE)	Seating capacity – persons		5	5
	Cargo space (L)		421	410
	Gross vehicle weight (kg)		2465	2550
	Maximum curb weight (kg)		1960	2055
	Running ground clearance ⁴ (mm)		182	212
	Towing capacity ⁵ – braked and unbraked (kg)		750	750 ⁵

MECHANICAL SPECIFICATIONS		bZ4X	bZ4X AWD
WHEELS	20" alloy wheels	•	•
	Tyre repair kit	•	•
PERFORMANCE	Maximum speed (km/h)	160	160
	Acceleration 0 to 100km/h	7.5	6.9
	Minimum turning radius (m)	Tyre = 5.6 / Body = 6.1	
	BEV driving range ^{6,7} (km) (NEDC)	436km (WLTP) ⁶ and 535km (NEDC) ⁶	411km (WLTP) ⁷ and 485km (NEDC) ⁷
	Electric energy consumption ^{6,7} (Wh/km) (NEDC)	168.9 Wh/km (WLTP) ⁶ and 128 Wh/km (NEDC) ⁶	181.1 Wh/km (WLTP) ⁷ and 141 Wh/km (NEDC) ⁷
COMFORT AND CONVENIENCE	Dual-zone climate control auto air conditioning	•	•
	Rear air vents	•	•
	Electric park brake	•	•
	Automatic rain sensing wipers	•	•
	Driver power front seat – 8-way	•	with memory
	Heated front seats – driver and passenger	•	•
	Ventilated seats – driver and passenger	•	•
	Heated steering wheel	•	•
	Cupholders – x2 front, x2 rear	•	•
EXTERIOR	LED Daytime Running Lamps	•	•
	Heated exterior mirrors	•	with memory and reverse auto adjust
	LED headlamps	•	•
	LED rear and eye level brake lights	•	•
	LED side mirror indicators	•	•
	Rear fog lamps	•	•
	Rear, side, quarter and back privacy glass	•	•
	Roof rails	•	•
	Rear spoiler	•	•
	Front and rear air spats	•	•
	Gloss black bonnet accent	•	•
	Two-tone roof	•	optional
INSTRUMENTS AND CONTROLS	Advanced park assist	•	•
	7" colour Multi Information Display (MID)	•	•
	Auto retractable door mirrors	•	•
	Power back door	•	with Kick Sensor
	Steering wheel with audio, phone, MID and Toyota Safety Sense controls	•	•
	12V socket	•	•
	Smart entry & smart start	•	•
	USB in centre console storage x3	•	•
	USB rear centre console x2	•	•
	Wireless phone charger	•	•
	Voice assistant	•	•
	Vehicle Stability Control (VSC)	•	•
	Downhill Assist Control (DAC), Multi Terrain Sensing and Crawl	•	accessible through X-Mode
	3 off-road modes (X-mode)	•	•
Tilt and telescopic steering wheel adjustment	•	•	
INTERIOR	Centre tray	•	•
	Cup holders – front x2	•	•
	Cup holders – rear x2	•	•
	Interior seat trim	Fabric and SofTex ^{®8}	Premium SofTex ^{®8}
	Leather accented steering wheel	•	•
	Heated steering wheel	•	•
	Rotary dial shift with integrated park brake	•	•
	60:40 folding rear seats	•	•
	Electrochromatic rear view interior mirror	•	•
	Personal front LED reading lamp	•	•
	Luggage compartment light	•	•
Fixed panoramic moon roof	•	•	
MULTIMEDIA	6 speakers	•	•
	9-speaker JBL [®] premium sound system	•	•
	12.3" multimedia system with cloud navigation	•	•
	Digital Audio Broadcast (DAB)	•	•
	Wireless Apple CarPlay [®] and Wireless Android Auto ^{™,9}	•	•

MECHANICAL SPECIFICATIONS		bZ4X	bZ4X AWD
SAFETY AND SECURITY	7 SRS Airbags	•	•
	Toyota Safety Sense ¹⁰ – including All-speed Active Cruise Control with curve speed reduction, Lane Departure Alert with steering assist, Lane Change Assist, Pre-Collision Safety system with pedestrian and daylight cyclist detection and Intersection Turn Assistance, Emergency Steering Assist, Road Sign Assist (speed signs only) and Automatic High Beam, Emergency Driving Stop System (EDSS)	•	•
	Blind Spot Monitor with Safe Exit Assist		•
	Rear Cross Traffic Alert		•
	Reversing camera	•	•
	Panoramic View Monitor		•
	Parking Support Brake (PKSB) with parking sensors	•	•
	Anti-lock Braking System with Electronic Brake-force Distribution and Brake Assist	•	•
	Rear seat occupant reminder	•	•
	Seatbelt reminder – all seats	•	•
	ISOFIX child restraint anchorage points x2 – rear outboard seats	•	•
First Aid kit	•	•	
TOYOTA CONNECTED SERVICES	Toyota Connected Services with Charge Management features including Safety and Security features, Driving Insights, Connected Multimedia and Remote Connect – accessible via myToyota Connect app ¹¹	•	•

1 Weights/mass/volumes/dimensions are approximate and subject to individual vehicle variances, and should be confirmed before fitting any accessories, towing or otherwise relying on this value.

2 Charging duration is approximate only and may vary depending on environmental and charging conditions, type of charger and method used. Actual charging times may differ. Frequent use of DC Fast Charging can impact battery performance & durability. Toyota recommends minimising DC Fast Charging usage. Refer to Owner's manual and toyota.com.au/electrified/battery-electric-vehicles/charging-your-bev for guidance.

3 Charging time when charging with a DC charger with 150kW (400 A) output.

4 Dimensions are approximate and are subject to individual vehicle variances, accessory fitment and weight carried.

5 Towing capacity subject to regulatory requirements, tow bar and vehicle design and towing equipment limitations. Ask your Dealer for Toyota Genuine tow bar capacity and availability details. Toyota Genuine Tow Bar not available for AWD grade.

6 535 km range, achieved for Australian electric bZ4X 2WD Automatic SUV, is based on consumption rate of 128 Wh/km using the NEDC combined drive cycle mandated by the ADR 81/02 (and is the range displayed on the Energy Consumption label affixed to the car). 436 km range, achieved for European electric bZ4X 2WD Automatic SUV, is based on consumption rate of 181.1Wh/km using the Worldwide Harmonised Light Vehicle Test Procedure (WLTP). Australian model has not been tested using WLTP test procedure. The electric range and the energy consumption values were determined using a fully charged battery in a laboratory test and should only be used for the purpose of comparing vehicles tested to the same technical procedures. Actual driving range may vary depending on accessories fitted, battery age and condition, climate, driving style, use of heating/cooling, traffic conditions, and vehicle load. The WLTP test cycle has higher energy demand compared to the NEDC which will generally deliver a lower driving range. For more information, please visit toyota.com.au/electrified/battery-electric-vehicles/charging-your-bev

7 485 km range, achieved for Australian electric bZ4X AWD Automatic SUV, is based on consumption rate of 141 Wh/km using the NEDC combined drive cycle mandated by the ADR 81/02 (and is the range displayed on the Energy Consumption label affixed to the car). 411 km range, achieved for European electric bZ4X AWD Automatic SUV, is based on consumption rate of 168.9Wh/km using the Worldwide Harmonised Light Vehicle Test Procedure (WLTP). Australian model has not been tested using WLTP test procedure. The electric range and the energy consumption values were determined using a fully charged battery in a laboratory test and should only be used for the purpose of comparing vehicles tested to the same technical procedures. Actual driving range may vary depending on accessories fitted, battery age and condition, climate, driving style, use of heating/cooling, traffic conditions, and vehicle load. The WLTP test cycle has higher energy demand compared to the NEDC which will generally deliver a lower driving range. For more information, please visit toyota.com.au/electrified/battery-electric-vehicles/charging-your-bev

8 Product and company names are trademarks of their respective owners.

9 CarPlay is a trademark of Apple, Inc. registered in the U.S. and other countries. Android Auto™ is a trademark of Google LLC.

10 Driver assist feature. Only operates under certain conditions. Check your Owner's Manual for explanation of limitations. Please drive safely.

11 Connected Services complimentary period ends 1 year from delivery date. Fees and charges may apply after. Requires activated DCM (until the earlier of 2033 or Telstra 4G sunset), compatible device, app installation/connection, third party info, mobile data, Australian network reception, GPS signal, enabled push notifications and other factors outside Toyota's control which can limit functionality. Mobile usage at user's cost. Features vary depending on vehicle model & subscription choice, and subject to change. For details see toyota.com.au/connected/connect-app

IMPORTANT NOTICE – PLEASE READ:

Toyota Australia uses its best endeavours to ensure material is accurate at the time of publishing. All information must be confirmed with your Toyota Dealer at the time of ordering, as specifications, applicability and availability may change over time. Colours depicted are a guide only and may vary from actual colours due to the printing/display process. Toyota Australia reserves the right to change and/or discontinue, without notice, models, prices, colours, materials, equipment, specifications. To the extent permitted by law, Toyota Australia will not be liable for any damage or loss incurred from relying

on the information and images contained in this material. Distributed nationally (other than in Western Australia) by Toyota Motor Corporation Australia Limited ABN 64 009 686 097. Material distributed in Western Australia by or on behalf of Prestige Motors Pty Ltd (for vehicles) and by Eastpoint Pty Ltd (for parts/accessories). Toyota Australia makes no warranties regarding (and will not be liable for) accuracy of materials distributed in Western Australia. PROOF HQ: T2024-021237. GTP-007839-02.

VERSION: JUNE 2024.