

HOOKLOADERS & SKIPLoadERS

**A POWERFUL
WORLD**

LIFETIME EXCELLENCE

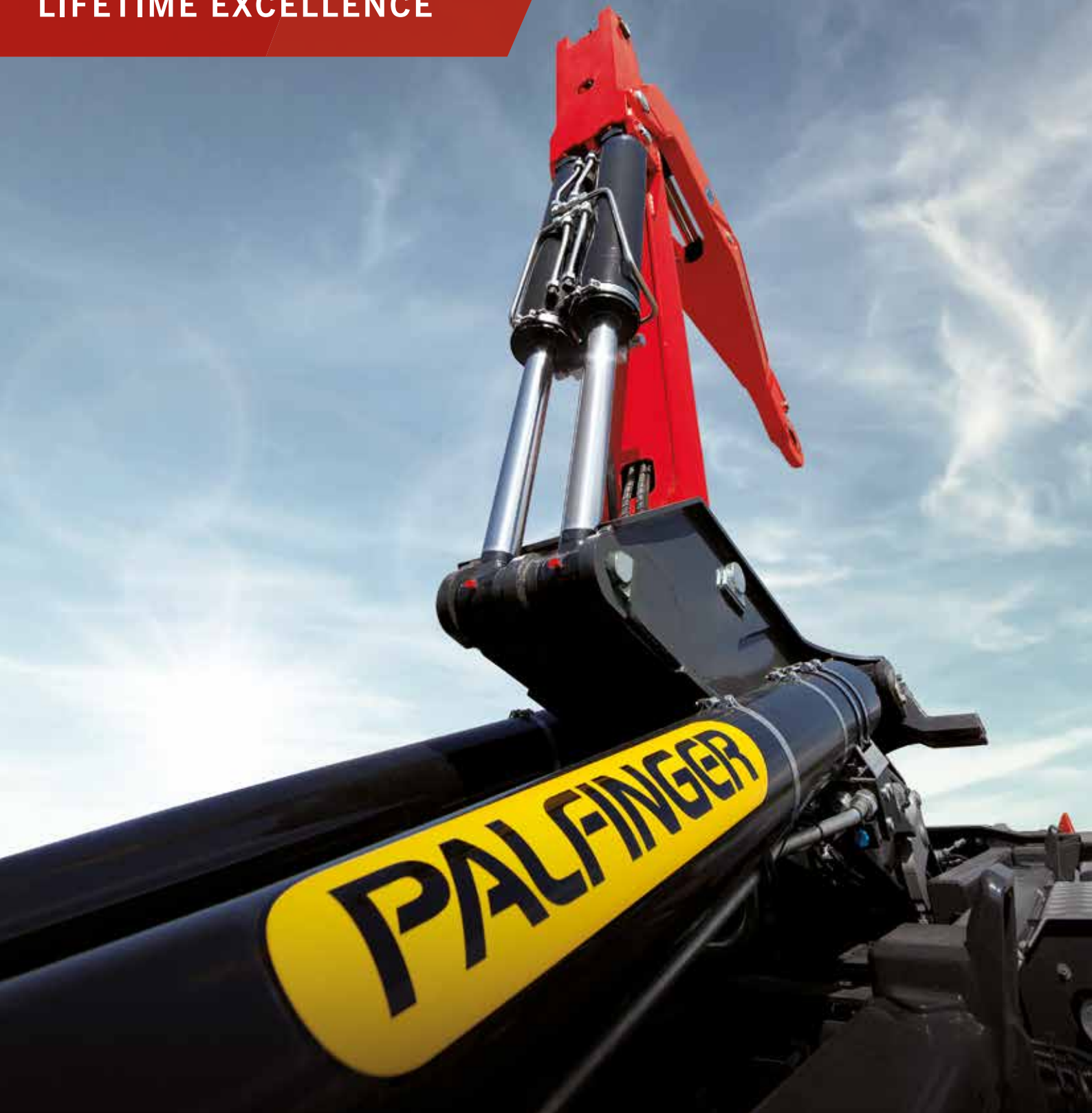

„FLEXIBILITY IS WHEN MY EMPLOYEES AUTOMATICALLY BECOME EXPERTS.“

Daniel Blackwood, Business Owner

CONTENT

LIFETIME EXCELLENCE	4
Hookloaders and Skiploaders	6
Center of Excellence	8
Sectors	10
Environment	12
Construction	14
Agriculture	16
Public Services	18
Army & Organizations	20
Craftsmen	22
Highlights	24
Product Range	26







“LIFETIME EXCELLENCE” MEANS SETTING TOP PERFORMANCE, AS A MINIMUM REQUIREMENT

LIFETIME EXCELLENCE is our promise. Our central message. The core of our brand. For our customers, it means uncompromising top performance. The most economical, reliable and innovative lifting solutions in a global network of professional service partners – for the lifetime of the product.

Excellence

Reliability & Expertise

PALFINGER products offer an outstanding price-performance ratio. High productivity, ease of use, a close-knit service network as well as high resale value more than pay for the investment in a PALFINGER product over the period of its use.

Support

Excellence

Flexibility & Innovation

Premium quality and strength of the products, durable components and outstanding workmanship, dependable worldwide service as well as the company's stability and strength make PALFINGER a reliable partner for professionals.

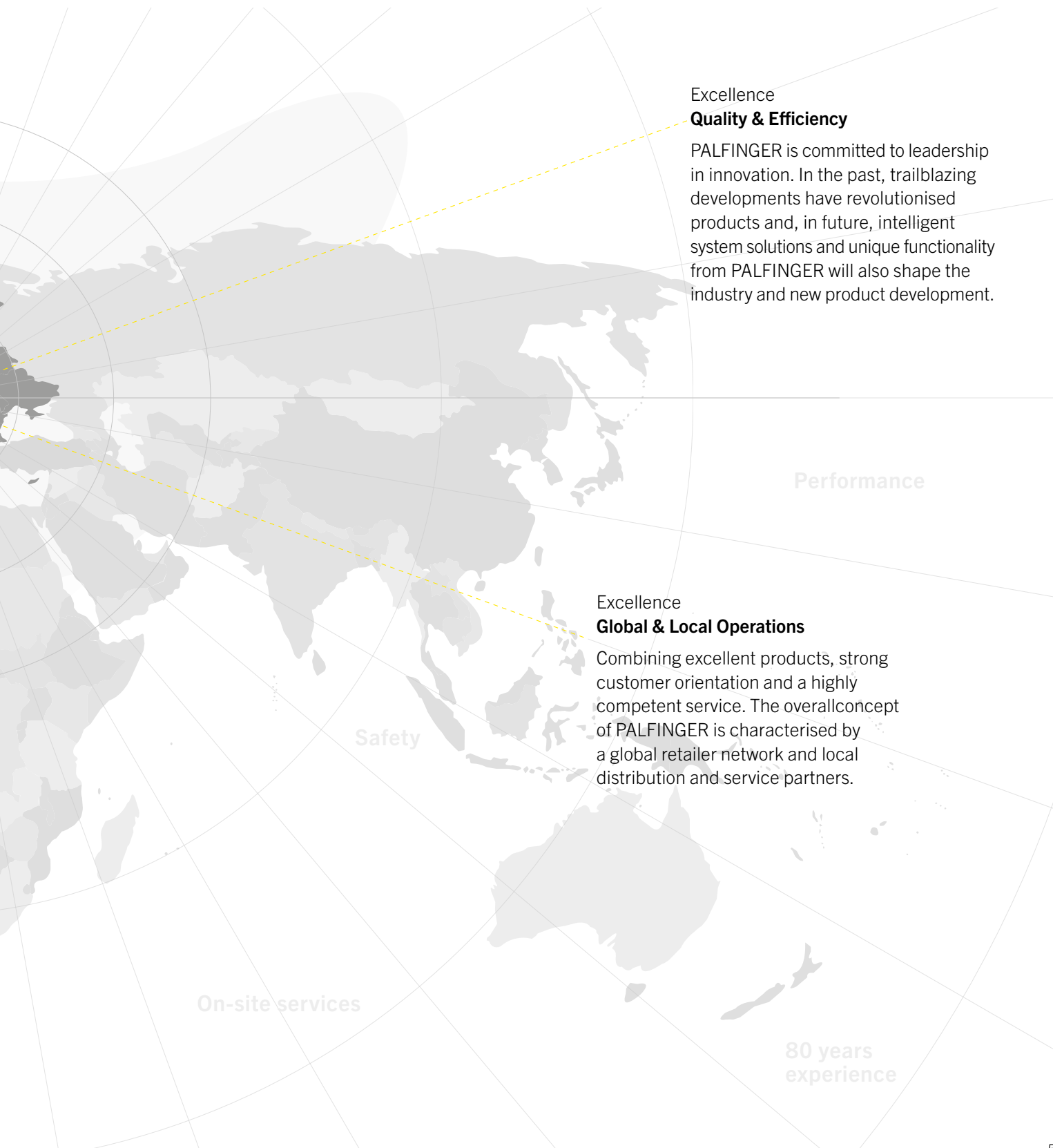

Excellence
Quality & Efficiency

PALFINGER is committed to leadership in innovation. In the past, trailblazing developments have revolutionised products and, in future, intelligent system solutions and unique functionality from PALFINGER will also shape the industry and new product development.

Performance

Excellence
Global & Local Operations

Combining excellent products, strong customer orientation and a highly competent service. The overall concept of PALFINGER is characterised by a global retailer network and local distribution and service partners.

Safety

On-site services

80 years
experience

PALFINGER HOOKLOADERS & SKIPLoadERS

PALFINGER Hooklifts is the most extensive brand of lifting equipment designed for movable containers. In this field, each application has its own requirement which has been fulfilled by PALFINGER during the last 40 years, all over the world.

We are committed to the highest quality and safety standards. State of the art industrial and quality organization allows us to occupy a leading position in the global movable container industry.

User friendly units are state of the art designed to fit the most demanded application needs. Special coating and high-quality materials guarantee resistance and maximum usage even under tough conditions.

The functional design of our Hookloaders and Skiploader provides easy service and low maintenance. This ensures high value retention and best operation cost, under safe conditions. A worldwide service network, including supply of spare parts ensures fast and reliable service.

Efficiency

Efficiency means high product quality with exceptional returns

- Each truck one solution
- Service friendly design
- Spare parts availability
- Very short delivery time for specific equipment
- High resale value

Reliability

Reliability means technology that can withstand the harshest conditions

- Benefit from experience
- High tensile steel design
- Industrial organization
- Close partnership with truck manufacturers

Innovation

Innovation means to make ground-breaking market-ready technology

- Pro Active Drive controls
- Maintenance free bushes
- "Ready to go" units
- Surface treated & certified accessories
- Approved bolted mounting





PALFINGER HOOKLIFTS CENTER OF EXCELLENCE

- A worldwide network
- Over 45 years experience in Hookloaders
- The widest equipment range
- A fully integrated process
- A strong focus on after sales and service

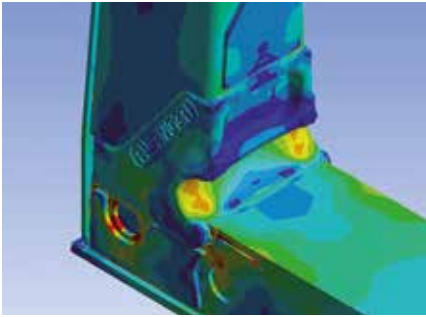

State of the art engineering

- Hookloaders and skiploader headquarters of the PALFINGER Group
- Validation of new developments (finite elements calculation, test bench, field tests)



Best in class

- Full traceability of welding, assembling and control operations
- Certified: ISO 9001 Quality - ISO 14001 Environment - OHSAS 18001 Health and Safety - ISO 3834 Welding



Service champion

- A network of professionals in industrial bodywork
- Technicians and salesmen training on our production site



After sales

- Spare parts easily available with a dedicated workshop
- Easy maintenance with a highly qualified staff and network



Truck mounting workshop

- "Ready to use" solutions, design of highly specified mounting accessories
- Training site for worldwide network



Pacwin.NET

- Pacwin a load distribution software specific for PALFINGER product lines
- All documents (spare parts catalogues, technical datas, mounting instructions) are available online





STRONG PERFORMANCE

LARGE AREA OF INDUSTRIES

Our wide range guarantees the highest vehicle usage for your applications.



Environment

- Recycling
- Scrap
- Refuse
- Garbage



Construction

- Building construction
- Civil engineering
- Material transport
- Carpentry



Agriculture

- Farming
- Harvesting
- Forestry
- Palm oil

Public services

- Municipalities
- Fire brigades
- Road maintenance
- Motorway



Army & Organizations

- Logistics
- UN
- NGOs
- NATO



Craftsmen

- Gardening
- Bricklaying
- Waste collection
- Municipal services



ENVIRONMENT

Wide range of duties in the waste disposal and recycling sector : Waste companies collect, transport, sort out, transform and recycle waste from industry and civil customers. The collection of the goods is done through containers which are filled permanently by the customers and picked up frequently.

The PALFINGER Hookloader with its favourable dead weight and its high lifting capacity is ideal for efficient container handling in the recycling industry. Short transfer and tipping times guarantee optimized loading cycles.





CONSTRUCTION

Building and construction companies need to transport construction machinery and other working machines (excavators, forklift, etc ...), they also load sand, gravel and other building material like liquids (fuel, water), for their own use, on the other hand they also have to bring away the building material waste.

The PALFINGER Hookloader is suitable for an extremely wide range of duties in the construction industry. According to the requirements profile - e.g. manoeuvrable or robust – PALFINGER offers the right Hookloader for each job.





AGRICULTURE

The time for cutting and harvesting is generally short. The farming industry requires efficiency for workers and vehicles. With a Hookloader just one vehicle is needed: crops are thrown in the containers, which are collected and brought back to the farm. Out of season, with less work, farmers can use the vehicle for other applications (transport and building waste, recycling material transport, wood and timber transport, etc).

The PALFINGER Hookloader is perfect for carrying out harvesting work in agriculture.





PUBLIC SERVICES

Cities, fire brigades, road maintenance services have to manage a large variety of different duties with limited budgets. Therefore the truck has to be flexible and able to load all the different types of bodies. The hookloader concept in this case is very much appreciated.

The PALFINGER Hookloader (sometimes in combination with a loading crane) is the best solution for an extremely wide range of jobs in the municipal sector.





ARMY & ORGANIZATIONS

Transport of equipment and material for the military maneuvers: handling of bodies for emergency and disaster-relief duties such as flats, ISO containers, or movable containers.

The PALFINGER SCORPION developed specially for the army's needs offers the possibility to invest in a small number of trucks for various applications, to load directly ISO container and by storing on the trucks the handling frame, to load standard containers.





CRAFTSMEN

When the craftsman unloads the container, he can easily take his implements – lawnmower, mixer, wheelbarrow-fill the container , and when needed tip the load. Ideal for urban applications, the small size truck-container allows driving through very narrow streets.

Very intuitive to handle with its ergonomic cab controls, the PALFINGER CiTy is also maintenance free.





LOOKING FOR YOUR NEEDS



Longevity

- Longevity and robustness due to casted parts (such as hook, locking hooks, rear pivots, hinge supports, ...)
- Increased product lifetime; increased resale value

POP – Palfinger Origin Protection

- Increased lifetime: Before assembling the main components are sand-blasted, degreased, primer painted and electro statically final coated (according to customer specification)
All other parts are anticorrosion treated
- According ISO 12944 Class 3–15 years



Customer oriented design

- Low maintenance : Threads in the pins for easy removal, greasing free sliding parts ...
- Safety is a major focus of our developments (life time cycles tests, FEM calculations, risk analyses ...)

Optimized speeds

- BI SPEED : low speed to easily catch the container bar
- RAPID MOTION reduces cycle time by increasing the hookloader speed, (for use with empty container or without container)



Cab control

- Ergonomic and intuitive. All check lights are on the control
- Magnetic fastening and thin cable facilitate the cab control manipulation



Wide choice of options

- Front hydraulic locking, pneumatic safety latch, rear lifting device...
- Axle stabilizers, Underride protection



Soft Stop

- Soft landing after loading & tipping
- Saves the truck, the hookloader and the container from shocks & reduces noise



One for each

- A solution for each application
- On demand developments to fulfil your specific needs



SAM - Secured Advanced Mounting

- A Large Offer Of Corrosion Protected And Bolttable mounting brackets and accessories
- Guarantees high quality and longevity



OSS - One Stop Shop

- To standardize bodybuilding within our network, while more reliable completion date
- To offer to our network a wide selection of mounting accessories

THE WIDEST PRODUCT RANGE

The complete range offers the most appropriate solution that sticks to your needs.

The PALFINGER Hookloaders are adapted to all European standards NF, DIN, CHEM, DIN ACTS, SCAN, and other national standards. The large choice of options allows to fulfil your specific applications.

Feel free to contact your closest PALFINGER specialist on www.palfinger.com

HOOKLOADERS

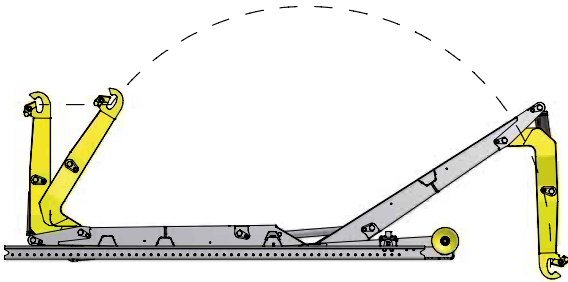

City from 2 to 4 tons

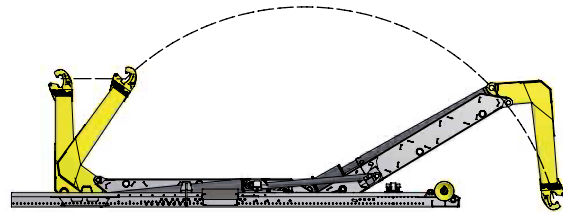

SYNCHRON from 8 to 21 tons

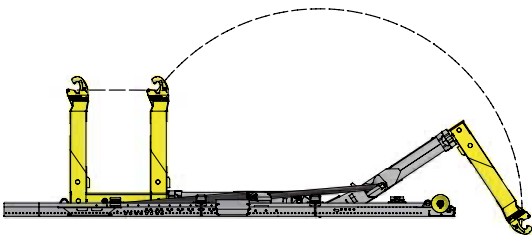

TELESCOPIC from 5 to 30 tons

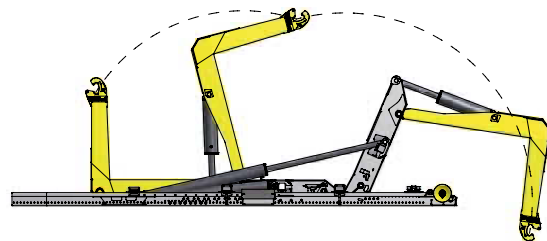

POWER from 8 to 24 tons

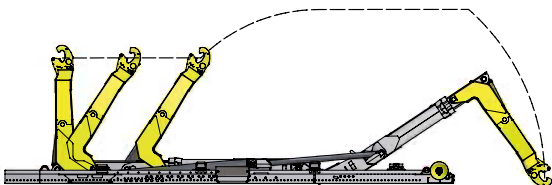

TELESCOPIC A from 13 to 26 tons

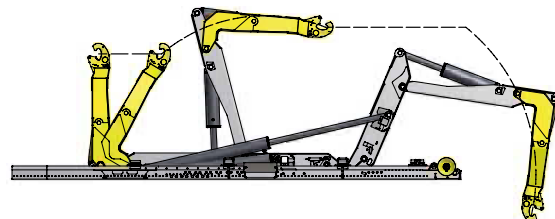

POWER A from 8 to 24 tons

SKIPLOADERS

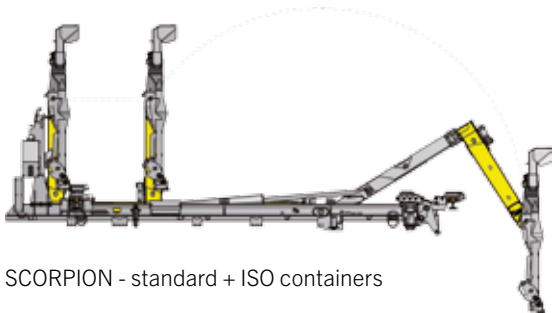

SCORPION - standard + ISO containers

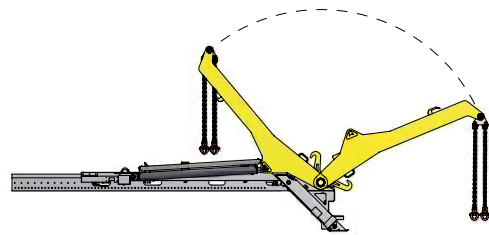

MULTI fix arms from 8 to 14 tons

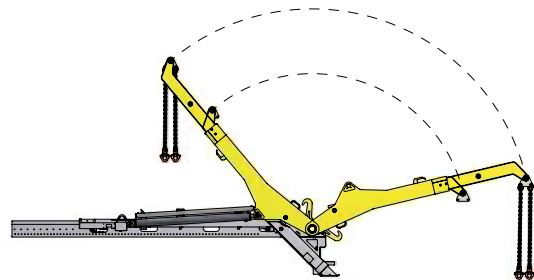

MULTI telescopic arms from 8 to 18 tons

GUIMA PALFINGER SAS
29 A AVENUE DES TOURONDES
82300 CAUSSADE – FRANCE

T +33 (0)5 63.26.22.22
info.guima@palfinger.com
www.palfinger.com