

PK 41002 EH

POWERFUL PERFORMANCE WITH LOW DEAD WEIGHT AND HIGH EFFICIENCY

LIFETIME EXCELLENCE



WIDE RANGE OF APPLICATIONS

- High value retention due to coating technology
- Additional applications with Power Link Plus
- Maximum utilisation of the working range due to HPSC
- More variety due to Fly-Jib





FIRST-RATE IN DESIGN AND PERFORMANCE



Power Link Plus

Wide-ranging applications

With the 15 degree reverse linkage system, you can reach through low door openings and also work inside buildings. Heavy crane work – even in difficult conditions.



Low-maintenance extension system

Reduces service time

With sliding elements made of synthetic material and the high-quality KTL coating, this boom system significantly simplifies service performed by the operator. This saves time and money – and protects the environment.



Coating technology

Top quality surface protection at a glance

The KTL coating lays the foundation for a perfect surface protection. Afterwards the components are either coated in the powder-coating facility or are finished with a two-components-topcoat. High value retention and excellent corrosion protection for the whole life of a crane.

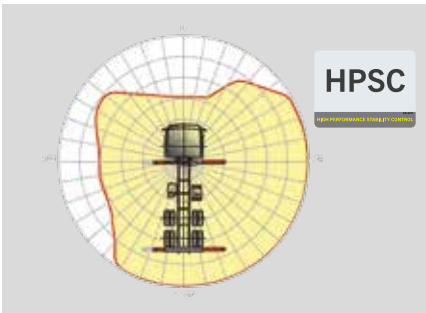

HPSC

Maximum utilisation of the working range

The variable stabiliser positioning of the High Performance Stability Control System allows the full lifting capacity of the crane to be used, even when working within tight spaces.



PAL 50

Comfort and safety

The PALTRONIC 50, PALFINGER offers the latest control electronics for the series production crane. The custom designed electronic operates and monitors the crane and offers more efficiency in use and safety.



Control console

All information at a glance

All important information about the crane can be seen on the main control stand. A digital indicator counts and displays the operating hours. Ergonomic control levers and the optional lighting package provide increased safety and comfort even in poor visibility conditions.



High Speed Extension

For efficient assignments

The High Speed Extension speeds up the extension boom system. Crane works faster and more efficiently.



Functional design

Practical and attractive

Robust plastic covers protect crane parts against dirt and damage. Improved looks and increased operational comfort – throughout the entire lifetime.



Radio remote control

Dialogue with the operator

PALFINGER radio remote controls are equipped with linear lever or cross lever and provide the greatest possible comfort for the operator. All EH models with LED-Display inform the crane operator about the different operating conditions.

PERFECT DIMENSIONS

Technical data

	PK 41002 EH	
Max. lifting moment	38,4 mt/376,7 kNm	277820 ft.lbs
Max. lifting capacity	14600 kg/143,2 kN	32190 lbs
Max. hydraulic outreach	16,3 m	53' 6"
Max. manual outreach	23,3 m	76' 5"
Slewing angle	400 °	
Slewing torque	4,0 mt/39,2 kNm	28940 ft.lbs
Stabiliser spread (std./max.)	6,6 m / 7,4 m	21' 9"/24' 3"
Fitting space required (std.)	1,28 m	4' 2"
Width folded	2,55 m	8' 4"
Max. operating pressure	350 bar	5075 psi
Recommended pump capacity	from 80 l/min to 100 l/min	21.1 US gal./min 26.4 US gal./min
Dead weight (std.)	3800 kg	8380 lbs

DIMENSIONS

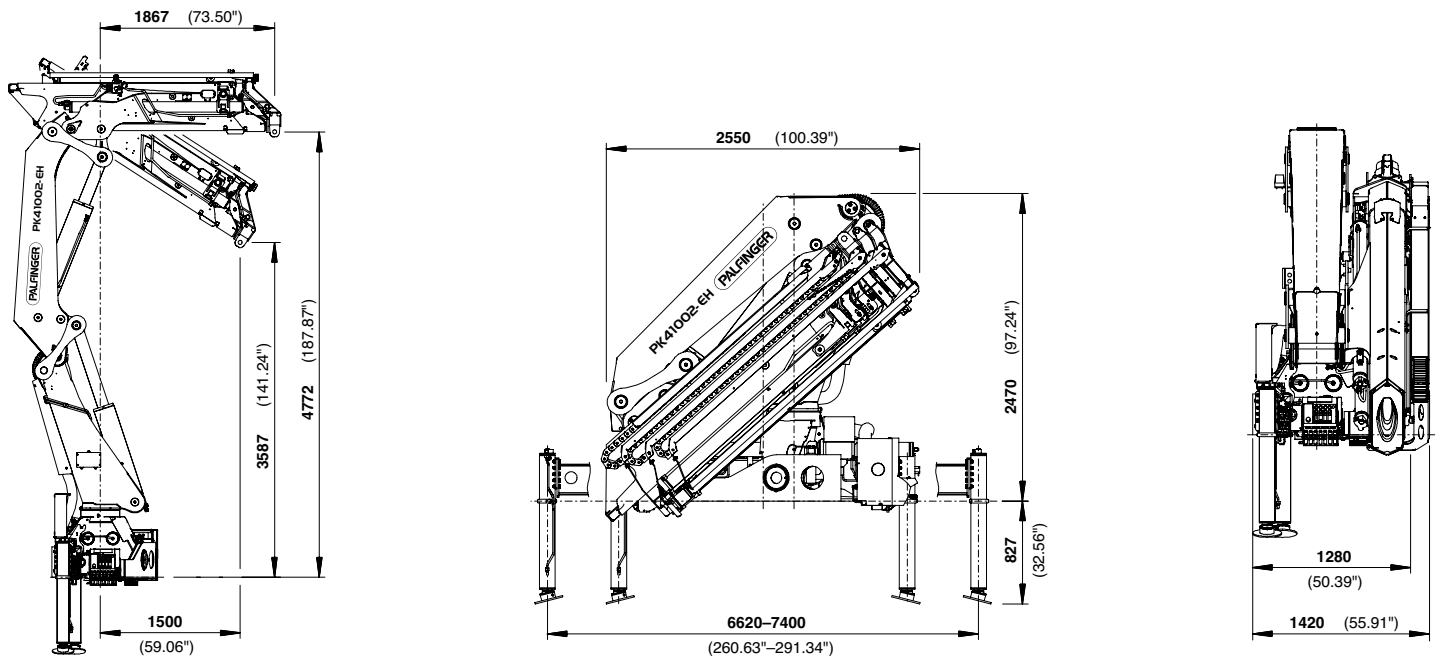

* Optional features / country-specific equipment



KP-PK41/36502M2+EN

Cranes shown in the leaflet are partially optional equipped and do not always correspond to the standard version. Country-specific regulations must be observed. Dimensions may vary. Subject to technical changes, errors and translation mistakes.