

ALLISON 05612 POWER TAKE-OFFS

OMFB is pleased to advise of an update to Allison 05612* model power take-offs. Previously, the location of one of the output-flange cap-screws (as indicated below) caused fouling with the transmission in some instances. The output-flange of the PTO has been rotated to relocate cap-screws either side of the obstructed area. It is now possible to fit this version of housing to all Allison 3000 & 4000 Series side and top PTO openings.

The updated version is already in circulation.

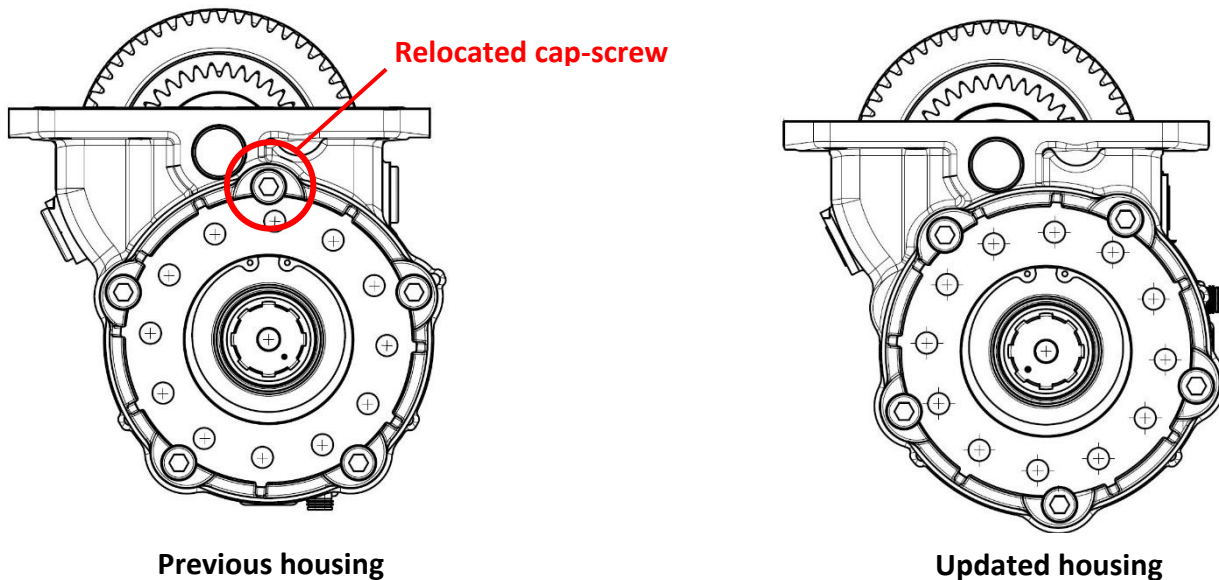

Relevant PTO models are:

- 05612512179 – PTO ALLISON PRECISION HS R1.18 12V V17
- 05612524175 – PTO ALLISON PRECISION HS R1.18 24V V17
- 05612612178 – PTO ALLISON PRECISION HS R1.01 12V V17
- 05612624174 – PTO ALLISON PRECISION HS R1.01 24V V17
- 05612912175 – PTO ALLISON PRECISION HS R1.44 12V V17
- 05612924171 – PTO ALLISON PRECISION HS R1.44 24V V17

Please contact the OMFB Pacific Sales Team for further information.