

RINGFEDER®

Automatic Trailer Couplings

suitable for drawbar eyes 40 acc. to DIN 74054 and 40 mm ISO 8755

Type 2020



Automatic Trailer Couplings

Type 2020

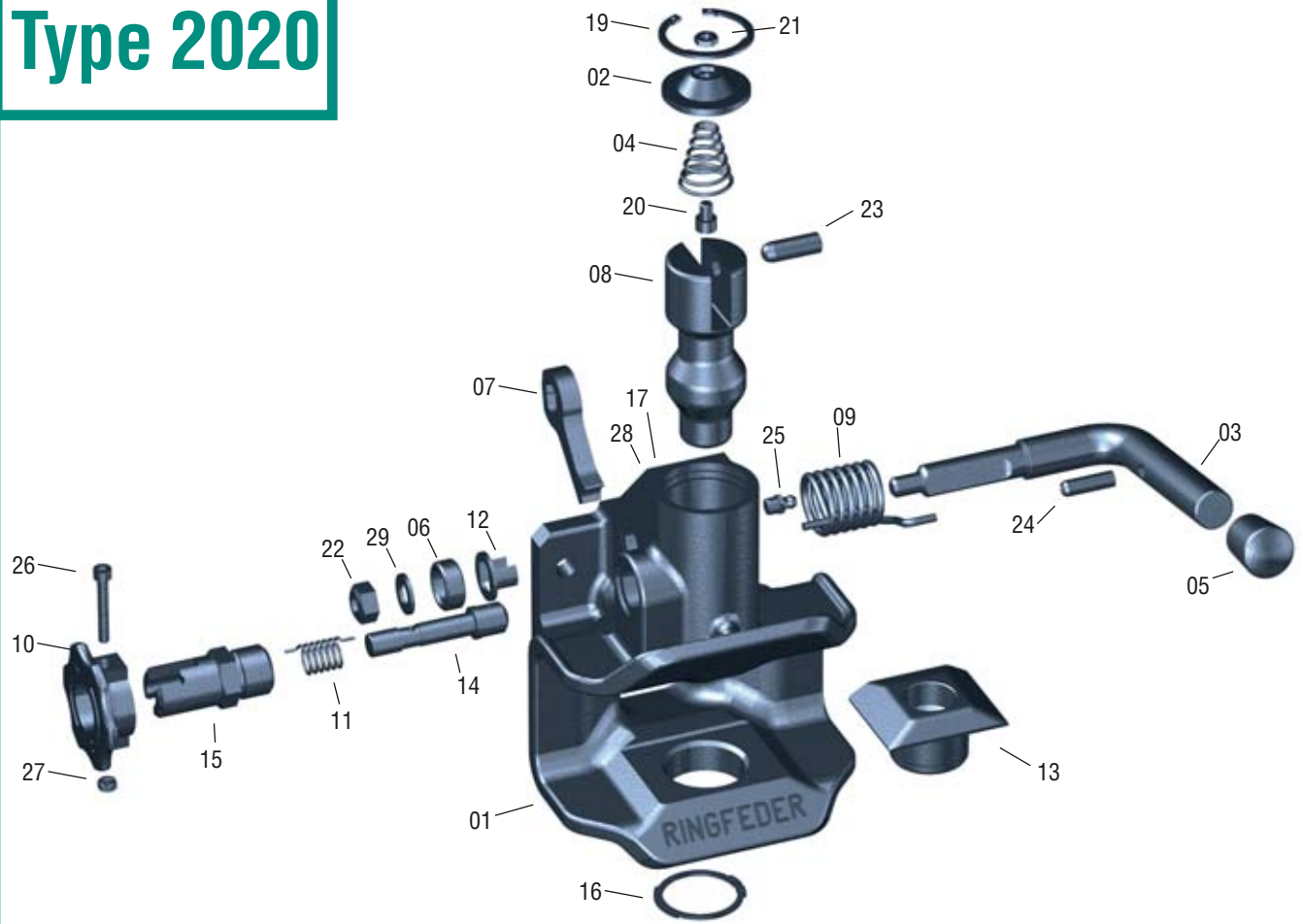

Parts list for replacement and maintenance

Item	Order No.	Description	Qty
01		Coupling mouth	1
		Coupling mouth	1
02	14 995 340	Top cover compl. incl. Pos. 4, 19, 20, 21	1
03	14 995 284	Handle / Locking lever Comb. incl. Pos. 5, 6, 7, 12, 22, 24, 29	1
04		Thrust spring	1
05		Cap for handle	1
06		Sleeve	1
07		Locking lever	1
08	14 995 324	Coupling bolt incl. Pos. 22, 23 ,29	1
09	14 995 428	Locking spring	1
10	14 995 292	Bolt-safety device compl. incl. Pos. 11, 14, 15, 26, 27	1
11		Turning spring	1
12		Distance washer	1
13	14 995 332	Wear plate incl. Pos. 16	1
14		Locking pin	1
15		Housing	1
16	DIN 471 38 x 1, 75	Retaining ring	1
17		Name plate	1

Item	Order No.	Description	Qty
18		Sticker	1
19	DIN 472 42 x 1, 75	Retaining ring	1
20	DIN 912 8.8 M6 x 8	Cylindrical screw	1
21	B M6 DIN 439 verz.	Hexagonal nut	1
22	DIN 980 M10 x 1,25	Safety nut	1
23	DIN 6325 ø 10 x 30	Cylindrical pin	1
24	DIN 1481 ø 8 x 26	Spring dovetail sleeve	1
25	DIN 71412 A M8 x 1	Grease nipple	1
26	DIN 912-8.8 M5 x 35	Cylindrical screw	1
27	DIN 934-8.8 M5	Hexagonal nut	1
28	DIN 1476-3x6-St	Buttonhead Rivet	4
29	DIN 126-B11 verz.	Washer	1

Installation and Operation

Range of application

Using of the coupling type 2020 for a D-value or Dc-value exceeding 18 kN is only permitted for such vehicles for which the use of bigger jaw-dimensions is impossible due to technical reasons and if, furthermore, there are special circumstances such as visual aids for ensuring safe execution of the automatic coupling procedure or, if the use is restricted for connection to centre axle trailers up to 3,5 tons maximum permissible mass.

Installation

When fitting (replacing) the trailer coupling please attend to the relevant statutory regulations and the particular information from the vehicle manufacturers. The installation of the mechanical coupling device to the vehicle is to be done in accordance with the requirements given in Annex VII of the directive 94/20 EC.

The automatic trailer couplings Ringfeder type 2020 are complete mounted and must be fitted with 4 hexagonal screws min quality 8.8 and 4 safety nuts min. quality 8 to the truck or trailer onto a plane plate at the vehicle with a flange size 120x55 or 83x56. Under nuts and screw heads you have to use washers DIN 125, hardness 200-250 HV. Alternatively to that you can use flange screws and safety flange nuts.

Version	Thread	Quality	Tightening torque
120 x 55	M 14	8.8	135 Nm
83 x 56	M 10	8.8	49 Nm

Operation

Coupling and uncoupling must be done acc. to the regulation to avoid accidents. To avoid getting in trouble, coupling and uncoupling should be done on plane streets.

Drawbar eyes on the trailer to be connected:

Drawbar eyes 40 DIN 74054 or drawbar eyes 40mm ISO 8755 or drawbar eyes class S acc. to directive 94/20 EC with the same dimensions.

Coupling

Make sure that the trailer is braked. Adjust drawbar eye to the height of the trailer coupling. Pull hand wheel of the bolt-safety device (10) of the trailer coupling outwards and turn it then clockwise until it stops. To open the coupling, move the handle (3) upwards until it engages. Now the coupling bolt (8) is on top and the coupling is ready to be connected. Drive back the truck slowly. When inserting the drawbar eye the coupling mechanism is released by lifting the coupling bolt. The coupling bolt slips through the drawbar eye bush and is automatically double secured in its lowest end position in the hole of the bottom guide bush (wear plate 13) by the locking lever (7) blocking up against the bevel of the coupling bolt and by the locking pin (14) of the bolt-safety device located over the coupling bolt. After each coupling process you have to check, if the bolt-safety device is completely inserted, which is perceptible (also by touch control) by the end plane of the locking pin is flush with the end plane of the housing of the bolt-safety device. Only in this working condition the trailer coupling is closed and double secured (see figures) so that the trailer may be operated. If the locking pin of the bolt-safety device protrudes over the housing of the bolt-safety device the trailer coupling is not closed and secured and the coupling procedure must be repeated.

Uncoupling

Make sure that the trailer is braked. Make sure that the trailer cannot roll forward or backwards. (Support drawbar of centre axle trailer by landing gears). Pull hand wheel of the bolt-safety device of the trailer coupling outwards and turn it then clockwise until it stops. To open the coupling, the handle is to move in its upper end position and then released (The handle engages in the upper end position). Now the coupling bolt is up, the coupling is ready for uncoupling. Separate the vehicles by driving the truck forwards. By driving out the drawbar eye, the coupling mechanism is released again by lifting the coupling bolt and the coupling closes automatically.

Maintenance

On every inspection and in regular intervals the trailer coupling should be checked for wear. The movable parts of the coupling will be subject to less wear if they are always kept well lubricated. In particular after cleaning with high – pressure washers the coupling has to be lubricated.

(Over grease nipple when the coupling is opened, opened to avoid trouble of function by over-lubrication, additionally the movable parts of the bolt-safety device)

Checking of wear according to installation- and operating instructions.

Technical Data:

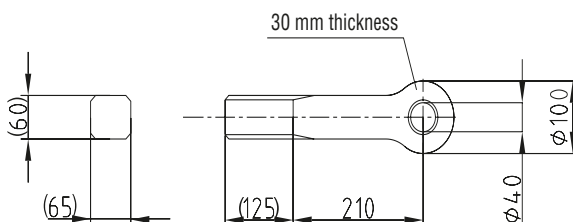

Drawbar eye 40 acc. to DIN 74054 or 40mm acc. to ISO 8755

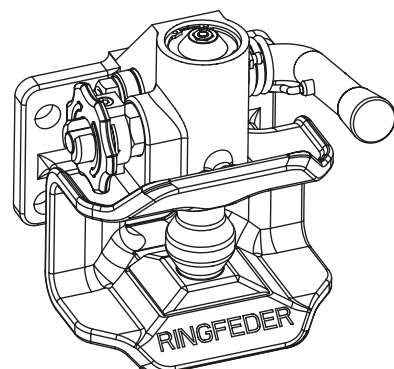

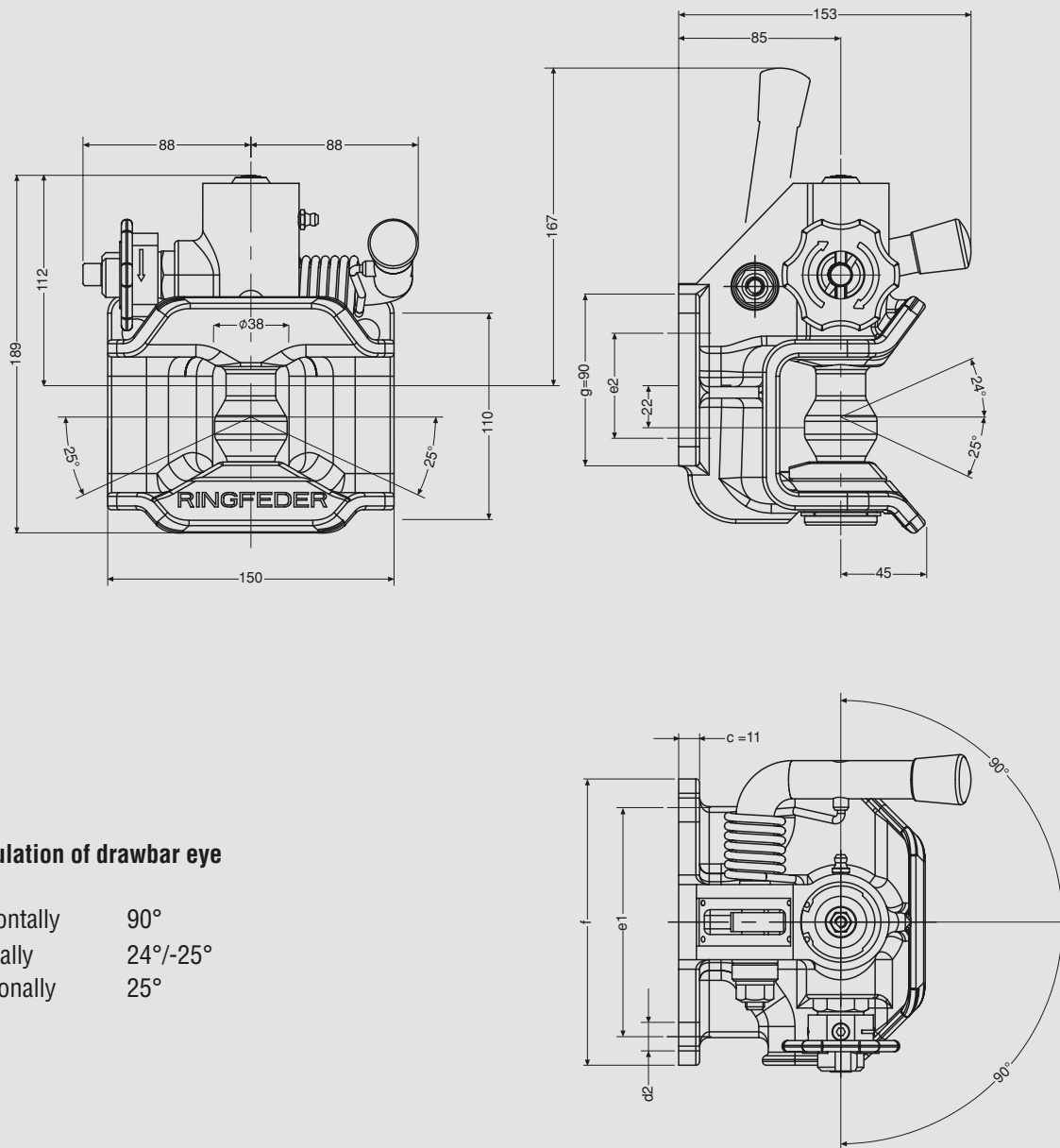

Articulation of drawbar eye

horizontally	90°
vertically	24°/-25°
rotationally	25°

Technical Data

Version / Flange design	Order No.	Type	94/20 EC-class	EEC Type Approval	D-Value kN	Dc-Value kN	V-Value kN	Admiss. Supporting Load / kg	c mm	d2 mm	e1 x e2 mm	f mm	g mm	Fastening Screws	Weight kg
83 x 56	14 996 141	2020	S	e1 00-1494	30*	30*	18	350	11	ø 10,5	83 x 56	110	90	M 10 - 8.8	5,8
120 x 55	14 996 116	2020	S	e1 00-1494	30*	30*	18	350	11	ø 15	120 x 55	150	90	M 14 - 8.8	6

* For a D-Value or Dc-Value exceeding 18 kN only to use for connection according to special range of application



A certified company in accordance with DIN EN ISO 9001 and DIN EN ISO 140001 and ISO TS 16949

RINGFEDER VBG GMBH · Oberslesienstr. 15 · D-47807 Krefeld · P.O. Box 130619 · D-47758 Krefeld
 Phone +49 (0) 2151 835-0 · Fax +49 (0) 2151 835-200/207 · <http://www.ringfeder.de>
 e-mail: info@ringfeder.de